

# CENTRIFUGAL PUMP SPECIFICATION AND SELECTION—A SYSTEM'S APPROACH

by

Stan T. Shiels

Senior Staff Engineer, Rotating Equipment

Esso Petroleum Canada

Dartmouth, Nova Scotia, Canada



*Stan T. Shiels is a Senior Rotating Equipment Engineer with Esso Petroleum Canada, a Division of Imperial Oil Limited, Canada. He joined Esso in 1981, and is currently responsible for the machinery management program at Dartmouth Refinery, Nova Scotia, Canada.*

*In previous assignments with Esso, Mr. Shiels has been involved in major machinery startups and machinery reliability audits, has served as consultant with the*

*company Technical Services Division in Toronto and was Machinery Engineering Supervisor at Sarnia Refinery, Ontario.*

*Prior to joining Esso, he was employed by Ontario Hydro, Canada where he was involved in plant commissioning and turbomachinery performance.*

*Mr. Shiels began his career in the United Kingdom as an engineering apprentice with Harland & Wolff, Limited, in Belfast.*

*He received his engineering degree in Scotland in 1965, is listed in the British Register of Chartered Engineers and is a Registered Professional Engineer in the Province of Ontario, Canada.*

## ABSTRACT

Proper pump specification and selection results in the best pump being purchased for the required service. Economic considerations may mean that "best" is not always the most efficient, best hydraulic fit or most expensive. As in most process or operational applications, the three primary areas of consideration are safety, reliability, and cost. Mechanical equipment requires periodic maintenance; therefore, maintainability must be included as a fourth area of concern.

Prioritizing these four is a first step. Pump specification proceeds from this point. The entire process of specification and selection is a team effort involving various disciplines. Typical areas and personnel involved are process/operations, design, rotating equipment specialist, and purchasing, mechanical, and vendors.

The complete process of centrifugal pump specification and selection is discussed as it involves these various disciplines. Primarily, some of the critical hydraulic areas of primary concern are addressed, along with the interrelationship between process requirements in these areas and the analytical approach to highlighting these areas in the selection process. The effect of pump design on suction specific speed, recommended minimum continuous flow and net positive suction head requirements are highlighted, together with process system variables which influence these parameters.

The process is sequential and proper completion requires clear definition of the first step. Specifying the pump is not the

first step after a brief review of boundary parameters. A full *system analysis* must precede pump specification. Pump vendors and most contractors are aware of this, but it is left to the user to address this need in the early stages. Only after completion of system analysis can we confidently proceed to *pump specification, bid request, bid review* and finally *pump selection*. The result of such a process is the selection of a pump which satisfies both process and mechanical needs.

## INTRODUCTION

Purchase of the right pump for the wrong service will often result when completion of a detailed system analysis is neglected prior to writing the specification. The performance of a centrifugal pump depends to a large extent upon correct specification and selection. Specification requires knowledge of the complete boundary conditions expected, variations on these conditions and any critical performance criteria. Failure to define or specify the pump for true expectations will result in poor operating experience and high maintenance costs.

In specifying a pump, the following process requirements are of prime importance:

- Maximum differential head requirement at rated and maximum flows.
- Net Positive Suction Head Available.
- Flow flexibility requirements—maximum and minimum flows.
- Fluid composition fluctuations and fluid temperature fluctuations.
- Transient conditions expected.

Accuracy in these critical areas and others is essential, and thorough system analysis will define these needs and result in correct specification data.

Unnecessarily conservative hydraulic requirements may drive a selection from single-stage overhung design to a more elaborate double-suction, single-stage between bearings design, or a multistage pump.

Mechanical seal selection and seal peripherals depend largely on fluid specification.

Having arrived at a correct pump specification, the requests for bids should include narrative statements detailing areas of importance or concern not included in the pump specification sheet.

The review of bids must include the preceding areas of importance and requires calculation of some hydraulic variables to permit proper evaluation. Mechanical properties also need careful consideration.

The degree of scrutiny required when reviewing bids will vary depending upon the complexity, and criticality of service. In general, a number of primary areas should be reviewed for all pump selections to ensure satisfactory services. Hydraulic considerations should include normal/rated flow as a percentage of best efficiency point (BEP) flow, the margin of NPSHA over net

positive suction head required (NPSHR), calculation of specific speed (S) and suction specific speed ( $S_s$ ), efficiency at rated flow and NPSHR variation over the operating range. Mechanical considerations should include vendor experience with similar designs, whether the pump is of single or double volute design, the L-10 life of the antifriction bearings, mechanical rigidity or resistance to moments and forces, a materials review, mechanical seal design and, not least, ease of maintainability. The pump selection will weigh various criteria to arrive to the optimum selection.

The details of each phase of centrifugal pump selection are dealt with, and some of the more recent findings of the industry are employed in matching requirements against the pumps offered. While all the steps in pump specification and selection are addressed, particular emphasis is given to hydraulic considerations where a correct match between a pump's capability and operational requirements is the objective. Some useful references in the area of mechanical design and pump reliability are included in the REFERENCES [3, 4, and 5]. These will amplify a more condensed approach taken herein.

## SYSTEM ANALYSIS

This first step toward the goal of selecting the proper pump for a service involves four primary areas of analysis:

- Pump Boundary Conditions
- Flow Requirements
- Fluid Specification
- Criticality of Service.

### Pump Boundary Conditions

Pump boundary conditions must be defined clearly and with as much certainty as is possible. A comprehensive knowledge of all boundary parameters is essential to correct user specification and vendor bid preparation.

Adequate suction conditions are critical to a centrifugal pump's operation. *Net positive suction head available (NPSHA)* must be determined. The margin between NPSHA and net positive suction head required (NPSHR) will have a direct bearing on pump performance and reliability.

When arriving at a value for NPSHA, it is necessary to consider the following:

- Does the calculated value for NPSHA allow for increases in system resistance in the suction piping due to fouling? Dirty

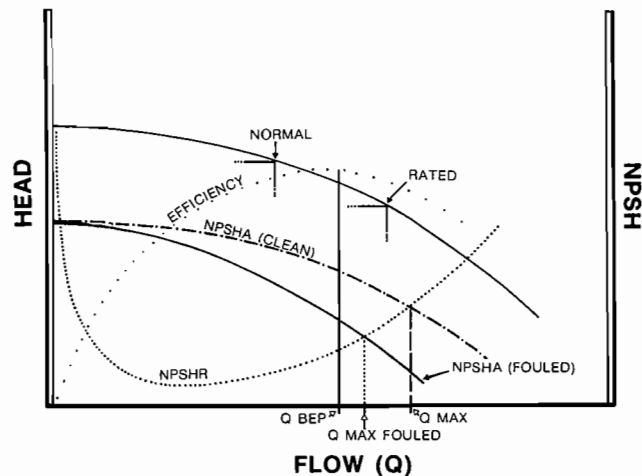

Figure 1. NPSHA vs Flow. (Effect of fouling on NPSHA and flow.)

fluids cause fouling of pipes, heat exchangers, strainers, etc. Even relatively clean fluids cause some degree of fouling. The extent of this fouling between cleanings must be accounted and allowed for, and this relationship is shown in Figure 1. The maximum capacity of a pump under clean conditions may fall off rapidly due to insufficient NPSHA under fouled conditions. A similar effect to that experienced through suction fouling may be experienced where direct radiant heat is allowed to increase the temperature in a long section of suction piping. The added heat between the suction vessel and the pump will reduce the margin between the NPSHA and the NPSHR, reducing the limit of maximum flow accordingly. Pipe insulation may assist here.

- Where suction is from a vessel, was the minimum possible operating level used in calculating NPSHA? The minimum possible level may mean the level at which a low level alarm comes in or may simply be the level of the takeoff pipe on a vessel. The structural design and process operational limits must be considered and the minimum level at which maximum flow is expected should provide the limiting guidelines here.

- What margin between NPSHA and NPSHR is considered as acceptable? Generally, pump vendors consider a three percent drop in head at a given capacity as indication of developed cavitation. The reduced head is produced by maintaining pump speed and gradually reducing suction pressure at a fixed capacity until the total head produced by the pump is 97 percent of the original head. This is repeated for a number of capacities to arrive at the manufacturer's NPSHR curve. An alternative method is to hold the speed and suction pressure constant and decrease discharge pressure until further increases in capacity cease to occur and pump total head falls off. The three percent is again used to determine the capacity at which cavitation is assumed to have occurred. The NPSHR curve produced by such methods should be considered as adequate only for low-energy pumps operating close to best efficiency [1]. Operation of high-energy pumps (>650 ft head) at these minimal NPSHR values can result in cavitation damage. To compensate for current vendor practice in determining NPSHR, a conservative approach to setting NPSHA should be taken with the margin based on additional capital expenditure required to gain the required extra suction head. Figure 2 [10] shows the typical relationship which can exist between NPSHR quoted and that required to maintain impeller damage-free operation. This is discussed further under *Performance*.

- Has the maximum expected flow been used to set NPSHA? Where NPSHA is based on normal flow and not maximum (or

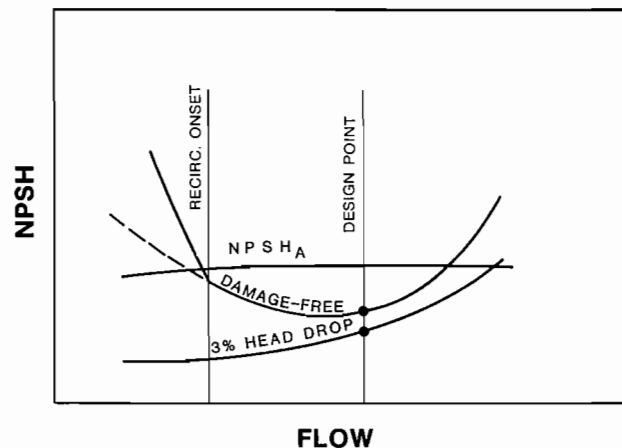

Figure 2. NPSH vs Flow. (A comparison of actual NPSHR vs NPSHR for damage free operation.)

rated), the rise in suction system resistance may preclude the expected maximum flow. This point is again illustrated in Figure 1.

Where NPSHA is minimal, and any increase in value will incur a major additional cost, it may be necessary to request vendors to pay special attention to NPSHR when submitting bids. To receive a pump which has an unrealistically low NPSHR curve will result in a heavy maintenance burden and unreliable operation. Bearing and seal life will be reduced. Impeller erosion will lead to a lower head/flow relationship and a fall-off in efficiency. A criteria of calculated NPSHR values as opposed to shop test values may be warranted.

Some degree of safety margin should be applied when comparing NPSHA to NPSHR. While the NPSHR is not known at this stage for vendors' pumps, a broad assumption can be made at this stage based on NPSHR being marginally lower (say 3 feet lower) than NPSHA at rated flow. Many contractors routinely build in such a typical safety margin. This will permit calculation of an approximate value of Suction Specific Speed ( $S_s$ ). As a general rule,  $S_s$  values above 11,000 are to be avoided, and the need to adjust some critical dimensions such as suction vessel height or suction pipe diameter may become evident through such early analysis.

$$S_s = \frac{N \sqrt{Q_{bep}}}{(NPSHR_{bep})^{0.75}}$$

Typical industry experience with centrifugal pumps of varying  $S_s$  is represented in Figure 3 [8], and the rapid rise in failure frequency when  $S_s$  exceeds 11,000 is shown. Although this is a broad generalization and does not correlate point of operation to BEP flow, the marked rise above 11,000  $S_s$  cannot be ignored.

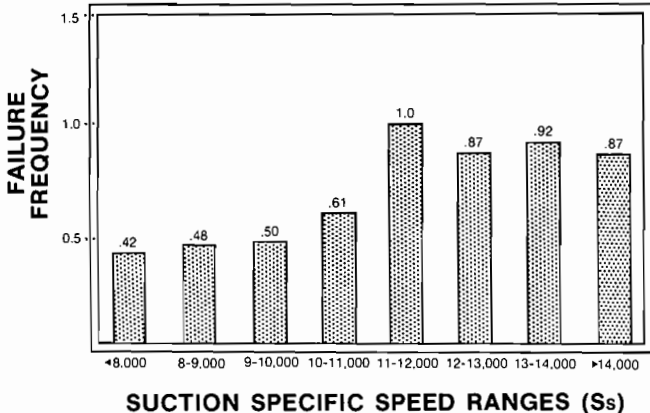

Figure 3. Failure Frequency vs Suction Specific Speed.

For a more detailed review of this subject and some useful formulas, see the Ross article [1] and the Palgrave and Cooper article [7]. A typical relationship between NPSHR by calculation and by suppression testing [1] is shown in Figure 4. In general, the three percent criteria used to establish NPSHR curves should not be accepted as a guideline for acceptable minimal NPSHA as cavitation will be well established in a pump operating at this NPSH level.

Pumps which develop high stage heads of greater than 650 feet and high suction specific speed ( $S_s$ ) pumps ( $S_s$  greater than 11,000) require greater than normal NPSH margins. A closer individual study is required. Where very high  $S_s$  pumps are necessary to fit the application, a suction backflow recirculation insert for the suction nozzle may be reviewed with the vendor. This can avoid cavitation surge which results when high  $S_s$  pumps are

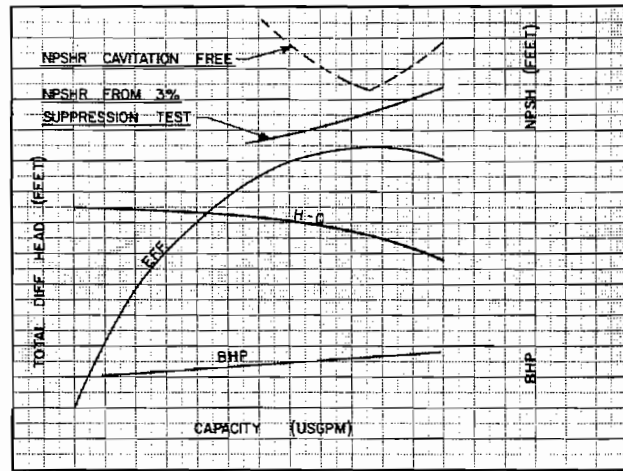

Figure 4. NPSH vs Flow. (A comparison of NPSHR to avoid cavitation vs NPSHR based on three percent head drop.)

operated at flows much below BEP (nominally less than 70 percent BEP, but dependent on Net NPSH (NPSHA-NPSHR) and  $S_s$  combination) [2].

The system resistance curve must be clearly defined. How much static head is built into the pump discharge in terms of downstream pressure in a receiving vessel, or height which must be overcome to reach the vessel? How quickly does the system resistance increase with flow? A quickly rising curve may preclude a maximum flow, expected periodically, which is considerably in excess of the normal flow. Control valve sizing will be affected by the rate of rise of the curve as will the size of pump. A larger than normal control valve may be required to provide the artificial head loss at rated and minimum flows, while still accommodating the low loss it must provide at maximum expected flow. The effect of system resistance on maximum possible flow and required control valve head loss is shown in Figure 5. In new installations, pipe size may be increased to flatten a steeply rising system resistance curve to accommodate greater flow flexibility.

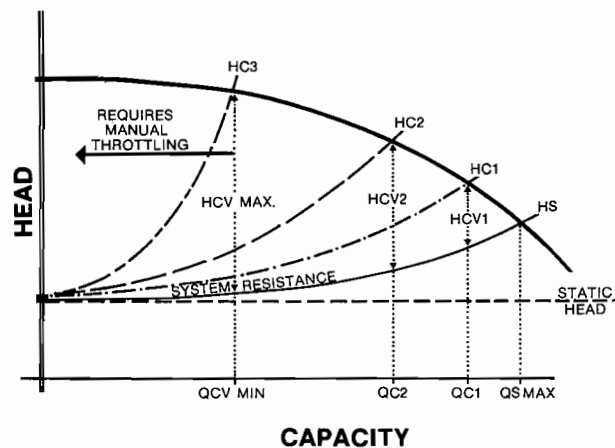

Figure 5. Control Valve Sizing. (Effect of system resistance on control valve sizing.)

The differential pressure which the pump will see will be derived from the system resistance curve. This must be converted to differential or total head (H). In arriving at H, the range of specific gravity (SG) expected must be reviewed, as any lower-

ing of SG will require additional pump head to meet required discharge pressure conditions. (Maximum head requirement should be based on the lowest expected SG. Horsepower requirements should be based on the highest expected SG.) Suction and discharge system resistance increases must be considered in arriving at a true value of maximum expected head for a given flow. Suction strainer plugging or heat exchanger fouling are typical of such increases in resistance and short cleaning intervals may be necessary where fouling is rapid. A new system, after chemical cleaning, will present the optimum cleanliness which is often not attainable thereafter, and this must also be factored into the initial calculations of resistance.

While defining system resistance to accommodate normal and changing conditions, it is also important not to be overly conservative. Imposing too high head values on a pump specification for given flows will result in the pump operating much below its BEP point, and in the lower efficiency region when these heads prove to be lower than expected. Reliability and maintenance costs will suffer likewise.

The static component of the discharge system resistance can also limit maximum capacity. Where the possibility exists of an increase in differential height between the liquid source and its delivery point or an increase in the pressure of the receiving downstream vessel, these must be looked at in determining rated conditions.

A simplified schematic diagram and head/flow curve illustrating these points is shown in Figure 6. Rated flow must be possible at the greatest expected total discharge system resistance.

Where the long range outlook may call for step changes in total static head, the type and size of pump must be tailored to accommodate such, through possible increases in impeller diameter. Space flexibility may permit a more flexible pump to

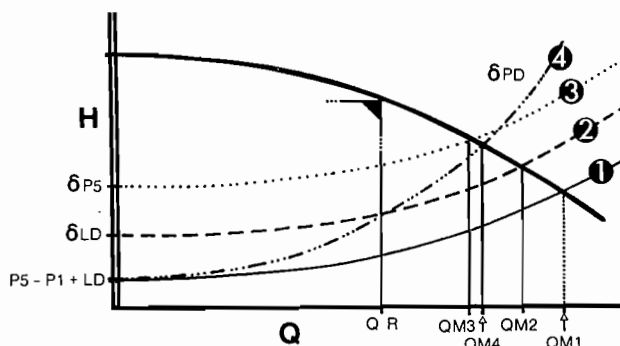
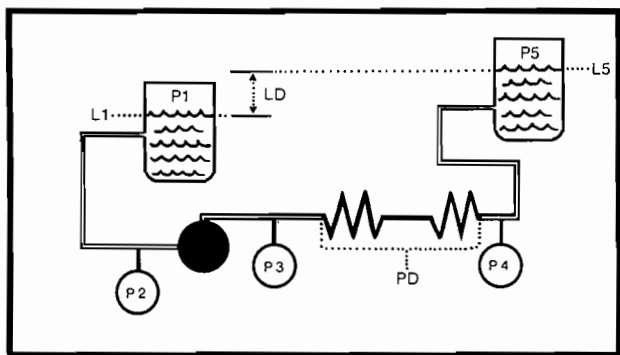

QR — RATED FLOW  
QM — MAXIMUM FLOW

Figure 6. Effect of System Resistance Variations on Maximum Possible Flow.

be offered (e.g., a double-suction between bearings versus a single-stage overhung or vertical inline design).

Flow Requirements

The purpose of this section is to present an approach which has been determined practicable and results in all necessary flow requirements being met. While there are many different opinions and papers on the subject of pump flow requirements, the following is based on personal experience with a workable approach utilizing some applicable industry findings.

Flows in the petroleum industry are generally termed "normal" and "rated." The normal flow is the flow at which the equipment will usually operate. The rated flow is the guaranteed flow at specified guarantee point operating conditions.

When determining these design flows, care must be taken to avoid an extremely conservative approach. This is another area where higher than expected flow requirements will result in a larger than required pump (as in head considerations). This may be further complicated where not only the size but the design of pump may be altered to comply with these high flows. A more simple single stage, overhung pump application may require a double-suction between bearings design under increased flow requirements. A simplified view of flow and head ranges is presented in Figure 7 for various types of centrifugal pumps operating at 60 Hz motor speeds.

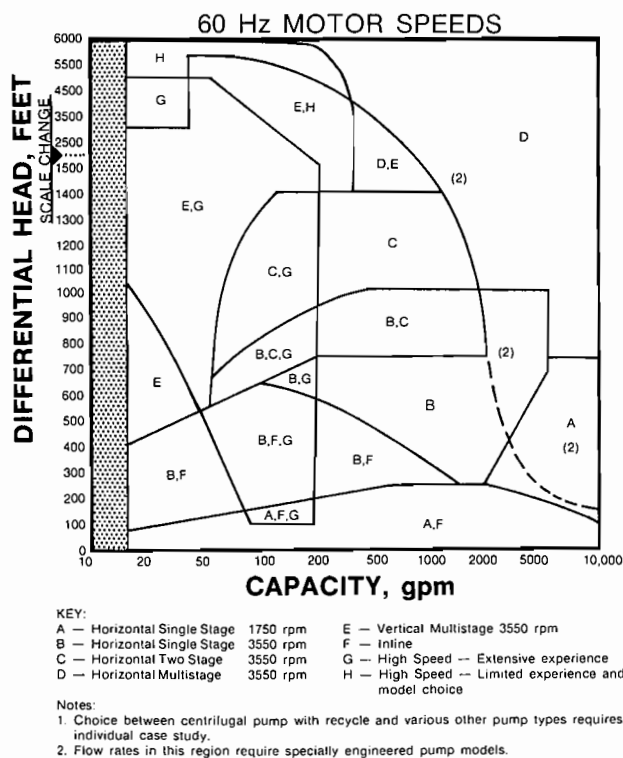
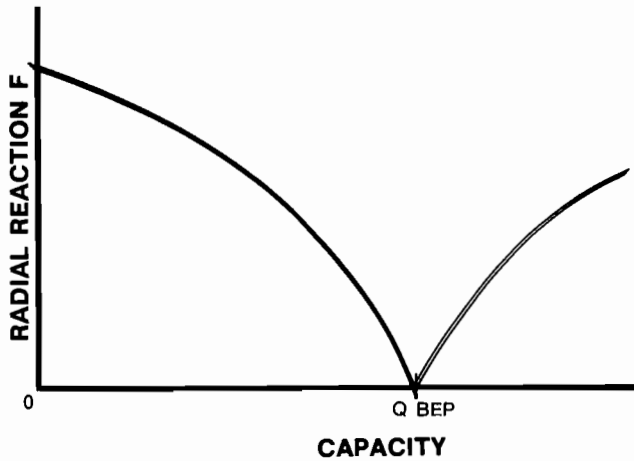

Figure 7. Application Range of Various Centrifugal Pump Construction Styles.

The rated flow should reflect the maximum flow the system can envisage under current consideration, but must also consider the long range outlook. Minimum flow requirements can conflict with rated requirements and recirculation facilities may be required.

While it is of prime importance to define maximum and minimum flow requirements properly, it is also important to clarify the percentage of time at which the pump will operate at

minimum, normal and, rated (or maximum) flows. Where a pump is used for two very different services, the lower flow may require excellent turndown while the higher flow will impose more stringent NPSHA restrictions. Longterm operation at the lower flow can mean higher maintenance costs due to higher bearing loads and shaft deflections. The relationship between radial bearing load and flow is shown in Figure 8. A general rule for rolling element bearings is that bearing life is inversely proportional to the cube of load.



NOTE: BEARING LIFE  $\propto \frac{1}{\text{LOAD}^3}$

Figure 8. Radial Reaction Force vs Capacity.

The possibility of physically or hydraulically shutting off the pump at its discharge must be considered. Recycle facilities may again be required to protect the pump.

Where complete *shutoff* (discharge isolation) of a pump is an expected occasional occurrence, provision must be made to recycle flow to prevent the pump from vapor locking, due to overheating of the trapped fluid. The minimum recycle flow required to protect from shutoff is a function of the time over which shutoff will be maintained and the ability of the pump to accommodate low flow conditions. The recycle requirements to protect the pump during shutoff conditions will generally be much less than required to protect the pump when operating at minimum continuous flow. Where shutoff will be for a short interval of minutes rather than hours, a recycle flow of 10 percent of BEP will normally suffice. For minimum continuous flow, a total flow of 30 to 40 percent of BEP is more realistic, although this can be much higher for high  $S_s$  and/or high head (H) pumps. Capital cost of recycle facilities is a major consideration here and the desirability of specific low flow (turn-down) capabilities must be highlighted.

Expected minimum continuous flow from an operational or process viewpoint may be less than is recommended for reliable, low maintenance service. Various hydraulically related factors and phenomena display themselves, and, in order of decreasing flow from the BEP point, may be listed as:

- suction recirculation
- discharge recirculation
- reduced impeller Life
- reduced bearing and seal life
- low flow cavitation
- high temperature rise

These are shown graphically in Figure 9. Generally, the first four listed will determine what minimum flow is considered acceptable.

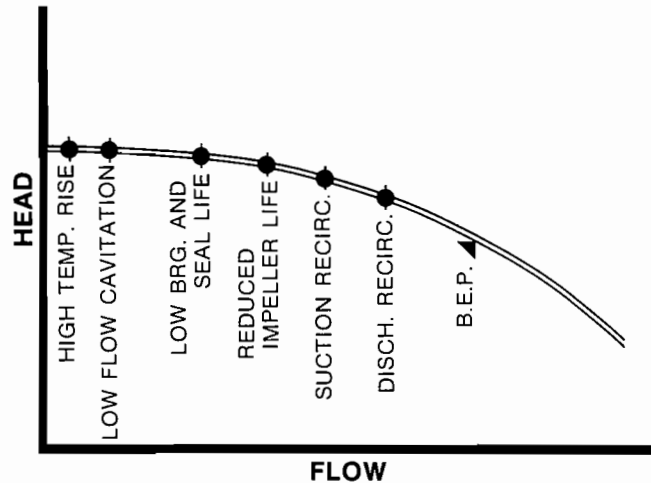
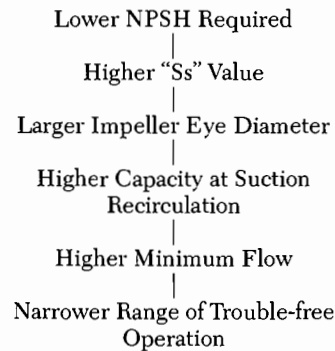

Figure 9. Head vs Flow Curve Illustrating Point of Onset of Events Which Adversely Affect Pump Operation.

The percentage of BEP flow at which *discharge and suction recirculation* within the impeller occur are a function of pump design and impeller geometry. For a given pump design, the flows at the onset of discharge and suction recirculation move closer to BEP as the suction specific speed ( $S_s$ ) increases. This means that pumps which require low values of NPSHR, and consequently have higher  $S_s$  values, will experience unstable flow patterns at a higher percentage of BEP.

The effects of the localized cavitation which occur due to impeller recirculation will increase in severity as flow is further reduced. A point will be reached where *normal impeller life* is significantly reduced with performance decline showing up after a short run time.

The effects of lower NPSH requirements may be shown as follows:



(Note: Where NPSHA is very low, a deep-well pump is often considered as an alternative, where the depth of the outer casing below suction flange centerline adds to the NPSHA.)

The location of suction and discharge recirculation within an impeller are shown in Figure 10. A graphical method for estimating the onset of suction recirculation is offered in Figures 11 and 12 [2]. Both  $S$  and  $S_s$  should be known. Again, estimates based on rated conditions may be used (together with NPSHA minus three feet as NPSHR) to estimate  $S$  and  $S_s$  and permit approximate flows for suction recirculation to be calculated.

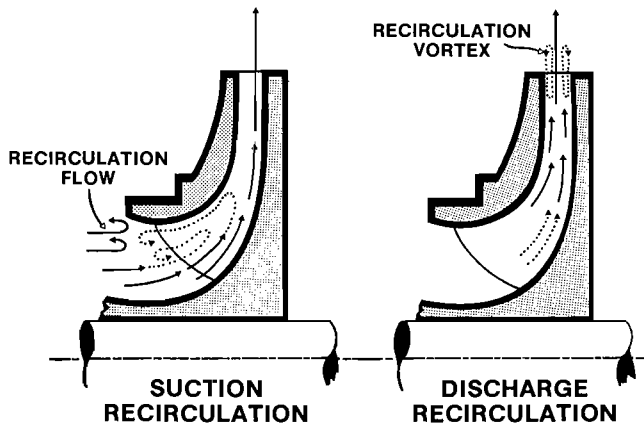

Figure 10. Position of Points of Suction and Discharge Recirculation within an Impeller.

As a general rule, the following acceptable minimum flows are recommended [2]:

- Water pumps operating at below 2500 USGPM and 150 feet head may operate satisfactorily at minimum flows of as low as 50 percent of the suction recirculation shown.
- For hydrocarbon operation, flows as low as 60 percent of the suction recirculation values shown may be accepted as satisfactory minimum continuous flows.

Operation below these regions can cause severe damage. The following symptoms and failures are evidence of impeller recirculation.

Discharge Recirculation

- cavitation damage at the vane's discharge on the pressure side of the vanes
- volute tip or diffuser tip cavitation damage

- axial shaft movement
- shaft failure on the outboard end of double-suction or multistage pumps
- damage to impeller shrouds at outer diameter can extend to complete impeller failure

Suction Recirculation

- cavitation damage at the vane's inlet on the pressure side of the vanes
- damage to suction stationary vanes
- suction surging
- random suction crackling noise (instead of steady crackling noise as associated with low NPSH cavitation)

The points of low flow cavitation and high temperature rise are only valid considerations where extremely low flows are considered probable for short periods which may cause severe cavitation and eventual vapor locking of the pump. Such events will rapidly lead to mechanical seal failure and require protection against even short duration of one to two minutes, where volatile liquids close to their vapor point are being pumped.

Localized damage areas within an impeller due to various types of cavitation are shown in Figure 13.

Knowledge of the foregoing considerations in regard to minimum flow will permit process designers to optimize design parameters for a pump to balance costs of surrounding structures and piping against expected pump performance. This is typical of an area where teamwork between the process designer, operations personnel, and the machinery specialist is essential.

For example, a pump requiring excellent turndown capabilities may be required to operate 90 percent or more of the time at a high flow. The energy gains from a high efficiency (and normally high  $S_s$ ) pump may offset the cost of a large recirculation flow facility for low flow operation.

The additional recirculation requirements to accommodate low minimum continuous flow in a high  $S_s$  pump (B) are compared in Figure 14 to a low  $S_s$  pump (A). Whereas, the minimum

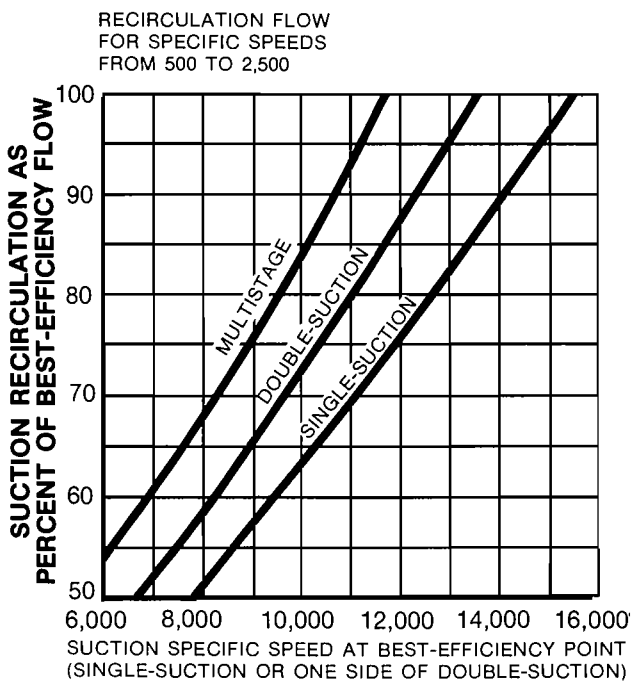

Figure 11. Recirculation Flow for Specific Speeds from 500 to 2,500.

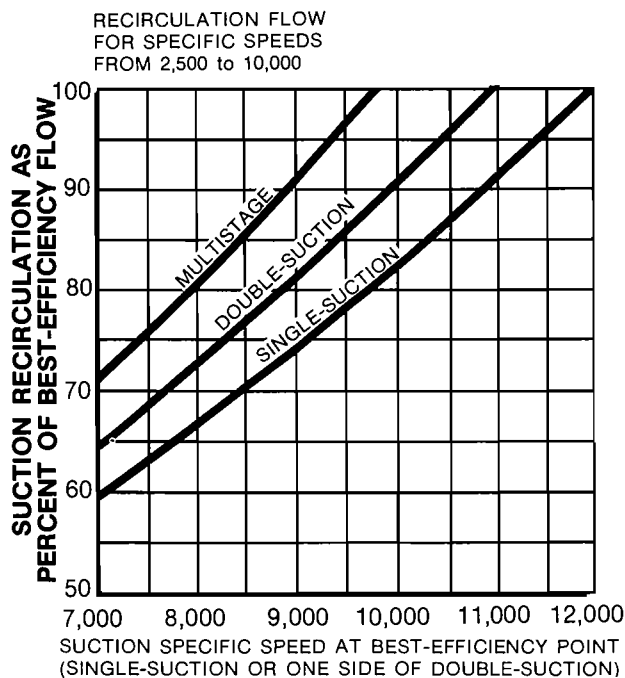

Figure 12. Recirculation Flow for Specific Speeds from 2,500 to 10,000.

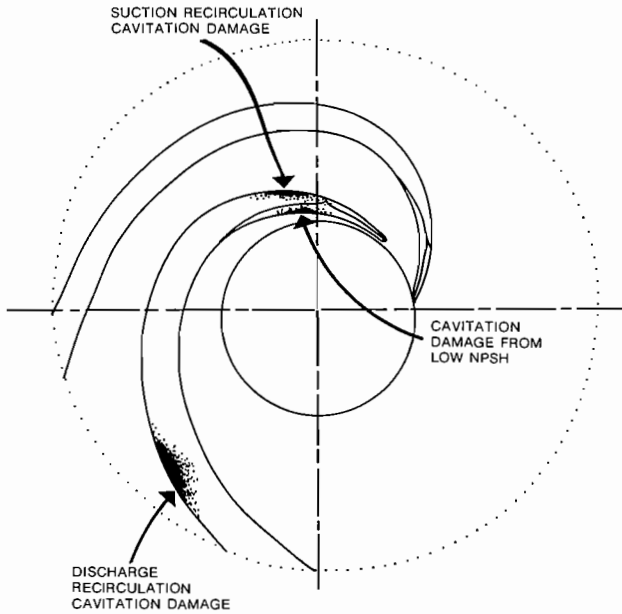

Figure 13. Areas of Damage Due to Cavitation Caused by Discharge Recirculation, Suction Recirculation, and Low NPSH.

continuous flow may be placed somewhere to the left of the onset of suction recirculation, the difference between the points of onset of recirculation is indicative of the additional recirculation flow required. Approximately 60 percent of this difference will represent the actual additional recirculation flow requirements.

Pumps with drooping head/flow curves, which result in a fall-off in maximum head towards shut-off, must operate well out towards the BEP point for adequate flow control stability.

The type of flow control must be considered. Level control if it fails, resulting in a fully open control valve, may allow a pump

to run out on its curve. A pump driver and NPSHA should be able to accommodate this and allow the pump to assume normal operation via manual control without motor trip or vapor locking. Flow rate control may be less likely to create similar problems, particularly where system resistance is a major part of the pump head. In any case, all types of flow control must consider what might happen to pump suction and discharge conditions under control failure. Where a pump is required to provide a dual service, the lower flow may again require a controlled recycle flow to maintain flow within the acceptable range.

When a pump is called upon to operate in parallel or series with another pump, additional care must be taken in defining each pump's boundary conditions.

Parallel operation requires that the minimum stable flow of all pumps, which are operating in parallel (two or more), be satisfied. Where pumps operating in parallel are not identical, the difference in shutoff heads may result in one pump being hydraulically shut off at a low flow within the operating range. A similar problem may occur at even higher flows where the head/capacity characteristic is very flat and shutoff heads differ.

While lower flow operation may not result in hydraulically shutting off one pump, it may result in one pump operating below its minimum stable flow point.

API 610 (6th edition) calls for one and two-stage pumps operating in parallel to have head rises of 10 to 20 percent of the head at rated capacity. This will protect identical pumps, but may endanger different sized pumps operating in parallel whose shut-off heads can differ while complying with this requirement. While the head rise requirement must be complied with, the agreement of parallel pump shut-off heads is equally important.

As a general rule, parallel operation of pumps to increase flow is most beneficial where the system resistance curve is relatively flat (or shallow) with respect to flow.

Series operation by nature, enforces identical flow through each pump where the discharge head of the pair (or more) is the sum of the heads developed by each pump. On occasion, however, sidestream flows may break this rule with the upstream pump delivering more flow than the downstream pump. The presence of resistive components and sidestreams have a major impact on setting pump boundary conditions where series operation is required. The split in head between the two pumps must reflect each pump's system resistance. Pressure limitations on system components such as heat exchangers may limit the maximum permissible pressure (or head) at a pump's discharge and may demand an uneven split in the pump's total head (or differential pressure). Series operation may also require the specification of a high pressure casing on the downstream pump, which may also require loss of flow protection in the event that it is unable to maintain a minimum flow if the upstream pump fails to deliver sufficient supply pressure. A typical series pump application with sidestream flow is shown in Figure 15.

As a general rule, series operation of pumps to increase flow is more beneficial than parallel operation where the system resistance curve is steep with respect to flow. Head/flow characteristics for simple series and parallel applications are shown in Figure 16.

Reliable operation, continuous satisfactory performance and low maintenance costs are only possible when such flow considerations are reviewed in a team framework at the system analysis stage.

Fluid Specification

System analysis must include a clear definition of the fluid to be pumped and show all variations expected in fluid quality. Materials selection, hard coatings, impeller design, mechanical seal design, driver horsepower and auxiliary piping are all affected by the qualities of the fluid to be pumped.

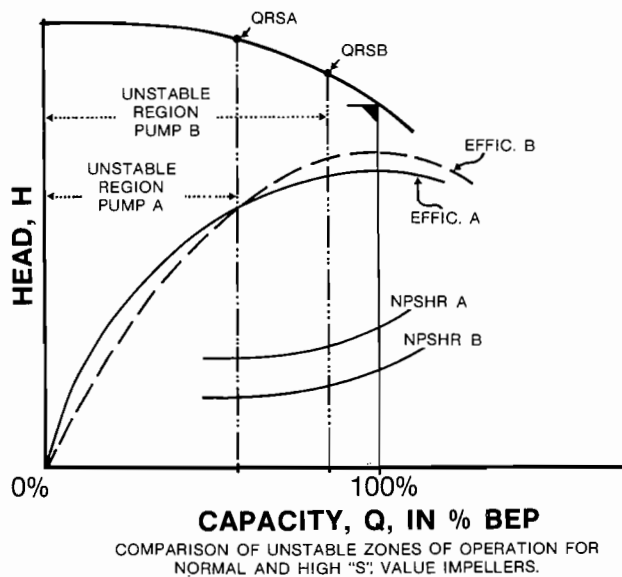

QRSA — FLOW AT SUCTION RECIRCULATION, PUMP A  
 QRSB — FLOW AT SUCTION RECIRCULATION, PUMP B

Figure 14. Comparison of Unstable Zones of Operation for Normal and High Ss Value Impellers.

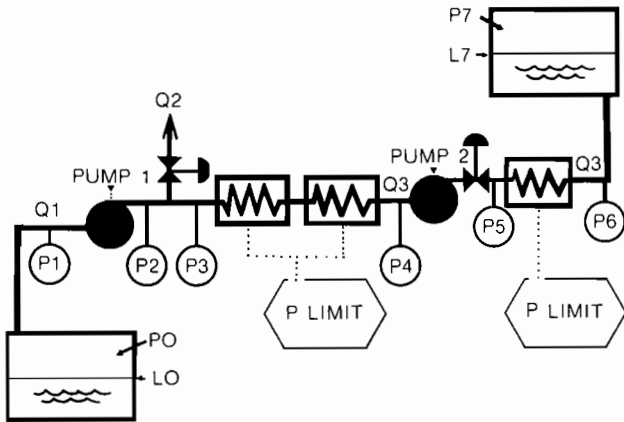

Figure 15. Schematic Presentation of Typical Series Pump Operation.

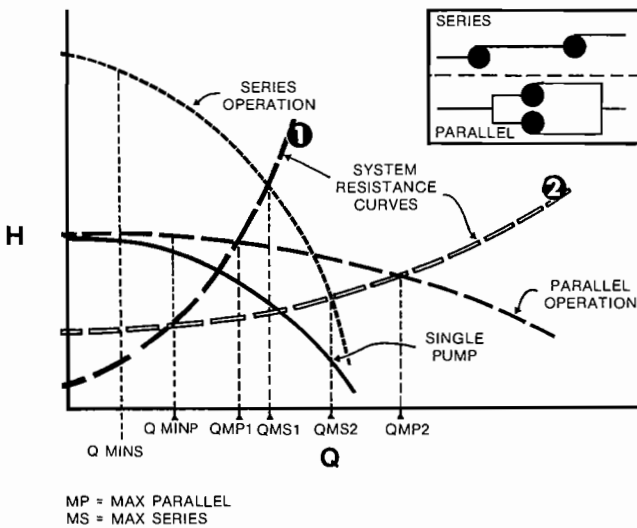

Figure 16. Pump Performance Curves for Parallel and Series Flow Operation Showing Effect of System Resistance.

Fluid temperature variations must be defined. This will assist in specifying the NPSHA and must include heating and cooling which may occur between the vessel or drum being drawn from and the pump suction, in the case of a vapor-liquid interface. Higher temperatures will necessitate bearing housing cooling and require that mechanical seal arrangements be suitably designed.

Corrosion due to chemical attack or oxidation must be considered. Compatibility of materials to resist electrolytic reaction is important. This is essential with salt water pumps in particular.

Erosion due to a high percentage of particulate matter may cause a premature performance decline. Large particles may necessitate an open-faced impeller. It may prove necessary to specify wear plates or a hard coating to prolong life. Wear ring flushing from an external source may be required.

Fluid toxicity may dictate the use of dual seals as may very high temperatures, high flammability, and/or high vapor pressures. Carcinogenic, strongly acid or strongly alkaline fluids impose similar needs for more elaborate sealing and often require an external clean fluid supply. It is imperative that these details be transmitted to the vendor in defining the fluid to be pumped.

Where a single pure fluid, such as water, is to be pumped, the onset of cavitation will be more marked and the damage caused

more severe than with some fluids comprising various chemistries such as mixed hydrocarbons.

Entrained gases may cause cavitation and may have a very negative effect on a pump's ability to produce the required differential pressure. These gases should be avoided where possible. Suction line venting to an upstream vessel may avoid a performance decline.

An accurate definition of the fluid to be pumped inclusive of all expected and potential variations is vital to a proper systems analysis and correct pump specification. It may be a simple exercise, as in the case of a firewater pump or boiler feedwater pump. Alternatively, it may require thorough analysis for some chemical, petrochemical or hydrocarbon process pumps. The analysis should always be completed accurately, as it has a direct bearing on many selection criteria.

#### Criticality of Service

##### Spared or Unspared?

Where a unit is dependent upon a pump for continued operation, a pump generally has a standby spare. Sometimes the two pumps are driven with different types of drivers—one with a motor and one with a steam turbine. This can further facilitate energy conservation, where excess steam may be available, and alone can offset the cost of carrying a spare pump, regardless of the process debits which would occur during a pump outage in single (unspared) pump operation.

##### Loss of Flow Process Debits

Where a specific time can be tolerated for a pump outage for maintenance, this must be considered under maintainability considerations. Ruggedness of design, maintainability needs and reparability are key areas here.

Safety consideration may require particular care in materials, mechanical seal and structural areas. Dangerous fluids which are toxic, carcinogenic or highly flammable demand more stringent design considerations. These are reviewed in more detail under PUMP SPECIFICATION.

Continuous operation is normally viewed as the prime criteria for sparing, but intermittent operation may also demand a spare pump. The definition of intermittent is important. A pump may be required to operate one week in four, but 24-hour service during that week may be crucial, requiring a spare for high reliability of service.

## PUMP SPECIFICATION

Pump specification is the step where definitions are made for the vendors (or prospective bidders) clarifying which requirements must be fulfilled and what options they have in certain areas. A list of "musts" and "wants" is provided and these are defined in a clearly displayed pump specification sheet—typically the API 610 standard centrifugal pump data sheet. Where a preference for a particular component is optional, the area may be left blank. In such cases, it becomes important to qualify any aspect of these blank areas which will be considered unacceptable, so that no particular vendor will be wrongly and unknowingly penalized for quoting an unacceptable item.

Narrative statements should accompany the centrifugal pump data sheet, to qualify in more detail those areas of importance which are only briefly described in the data sheet. A separate sheet for the mechanical seal specification is strongly recommended.

There are a number of prime areas of importance in specifying a centrifugal pump and the preparatory work done on system analysis will enable many of these areas to be defined confidently. As per the API 610 data sheet these include:



- liquid specification
- operating and site conditions
- performance
- construction
- mechanical seals
- auxiliary piping
- lubrication and bearings
- inspection and test
- vertical pump details
- weights
- additional information

#### Liquid Specification

In addition to the parameters outlined on the API 610 data sheet, comment must be made on *solids content*, *toxicity* and *setup temperature*. These latter three qualities of a liquid will play a large part in determining mechanical seal selection and auxiliary piping requirements as will many of the other liquid specifications.

It may be necessary to include an additional comment in the narrative statement to fully define special qualities of the liquid.

#### Operating and Site Conditions

The *capacity* is now defined to represent normal and maximum (or rated) conditions. Minimum expected continuous flow must also be included here. By defining these three flows, maximum, normal and minimum, vendor constraints are imposed, which must be considered in light of the other hydraulic specifications. Remember to include a table showing the percentage of time the pump is expected to run at each of these three flows.

*Suction pressure*, maximum, rated and, in particular, the minimum which may be experienced, will be given very serious consideration by the vendor when considering capacity requirements. (Excessive drop in pressure at the impeller eye at high flows forces designers to increase impeller eye diameter to accommodate low NPSHA.)

The maximum *discharge pressure* which will be encountered under conditions of maximum flow and minimum suction pressure will heavily influence the size and type of pump which a vendor must offer and may limit the choice.

It is necessary to be realistic in writing the pump specification. After full system analysis, the boundary conditions and flow requirements may preclude a vertical inline pump even though the plot space calls for such a pump to fit a limited space. A low flow, high head requirement may not fall within the range of a conventional centrifugal pump and may require a high speed, two (or multiple) stage or series pump operation.

The previously conducted system review will have considered the operating flexibility and space requirements of various pump designs in defining boundary conditions and flow requirements. The optimization performed under the system analysis will result in clear and easily definable pump hydraulic parameters.

*Site conditions* will influence items such as electrical or steam tracing requirements, lubricant quality, type of lubrication, motor protection, etc.

#### Performance

This relatively small area of the data sheet is of prime importance when bids are reviewed. The vendors (bidders) have an opportunity here to convey much of the important performance variables which will effect the selection. Strangely, this section is often partially neglected by bidders or the information submitted is erroneous. These critical parameters of minimum flow and

suction specific speed are often neglected or treated lightly. It is necessary to reinforce the requests for these details by being more descriptive of the performance needs in the section on Operating Conditions. In particular, where calculated values of NPSHR are considered to be more important than the normal test values, they must be specifically requested. Some debate is still ongoing on the correct formulas for calculating NPSHR values, and it may be some time before such a request can be considered standard.

The *minimum flow* based on stable conditions may be considered as a margin below the onset of impeller recirculation and the empirical data in Figures 11 and 12 permit a broad assessment of recirculation as a percentage of BEP based on specific speed ( $S$ ) and suction specific speed ( $S_s$ ). Since  $S_s$  demands an accurate representation of NPSHR, this must be emphasized to the bidders. Where NPSHA is considerably in excess of that required for a vendor's selected pump, he may supply an overly conservative NPSHR curve which will result in a low calculation of  $S_s$  and an erroneously high assessment of minimum stable flow.

#### Construction

The specification section dealing with pump *construction* incorporates four areas: *pump construction*, *mechanical seal construction*, *coupling type*, and *bearings/lubrication*. The API 610 data sheet includes details on the pump type, lubrication, coupling and the mechanical seal. The attention necessary in the specification of the mechanical seal demands a separate data sheet for this purpose. Mechanical seals, lubrication and bearings are dealt with in *Mechanical Seals* and *Lubrication and Bearings*, respectively.

It is advisable to specify the *coupling* type rather than leave this to the vendor's discretion. Dry spacer type disk couplings are often preferred and where specifying such, an added feature of a retained spacer will add safety in the event of a coupling failure. A proven alternative to the disk type coupling is the elastomeric coupling which is easily changed and is safe in failure. Gear type couplings are heavier for the same horsepower and require regreasing to give reliable service.

*Centerline supported pumps* are generally preferred over bracket supported. This will minimize misalignment due to thermal expansion. API pumps should be specified for fluid temperatures above 350°F. ANSI pumps are generally not centerline mounted and may not be suitable for some high temperature applications. Clearly specify a vertical inline if plot space does not permit a horizontal or high piping stresses are to be avoided. A vertical inline pump can be made free to move horizontally. Flange orientation and rating must be included.

Where a high degree of flow flexibility is required it is advisable to let the vendor know that a double volute pump casing is preferred to minimize radial loads at lower flows. This is not always possible nor as critical for smaller pumps where nozzle size does not always permit a double volute design.

#### Mechanical Seals

The reliability and service life of today's mechanical seals make them a preferred alternative to packing in most cases, and in particular, where essentially zero fluid leakage is desired. In many cases, shaft packing is considered acceptable, particularly in intermittent services involving clean low temperature, non-toxic fluids, such as cold water. Packing however, while easily adjusted and replaced, will cause severe shaft or shaft sleeve wear.

A separate mechanical seal data sheet should be attached to a pump specification, part of which is filled in by the purchaser and part by the seal vendor. Provided the mechanical seal manufacturer is in receipt of all liquid and operating data, he can

offer a seal which would be expected to give satisfactory service. Since not all seal vendors offer similar seal designs, it is best to be specific about which type of seal, from which vendor(s), are preferred. The seal selection should not be left to the pump vendor where he will often be encouraged to go with the lowest priced seal to reduce the overall cost of his proposed pump. This may pose a problem where inhouse knowledge of mechanical seal application is weak. Seal face material, balance ratio limits, auxiliary sealing arrangements and auxiliary seal piping arrangements are best specified by the purchaser, often in consultation with seal manufacturers or other knowledgeable specialists.

This area of the pump specification will effect pump reliability as much as, or more than, most other areas as mechanical seals are the major contributor to pump repairs. Some of the critical areas of mechanical seals are:

- seal type—stationary or rotating bellows seal, or pusher seal.
- seal face material and face width.
- secondary seal material (O-rings, gaskets, packing rings).
- auxiliary seal design.
- dual seal requirements (double or tandem).
- auxiliary piping needs (flush, quench and cooling).
- balance ratio.
- seal sleeve design or shaft mounted.

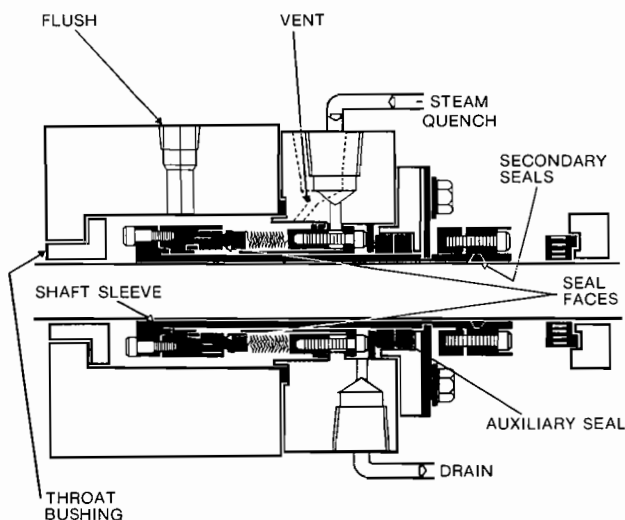

Figure 17. Stationary Metal Bellows Seal.

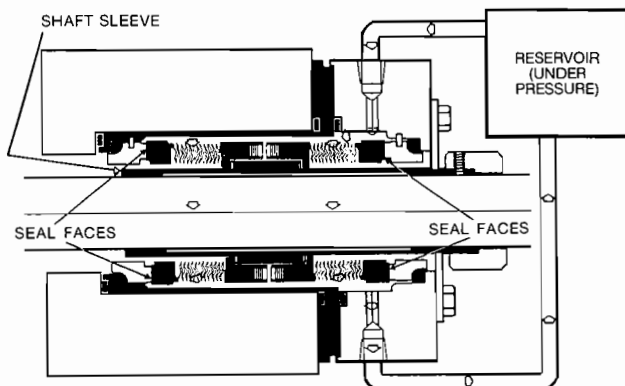

Figure 18. Double Metal Bellows Seal.

- throat bushing clearance.

Neglect in any of these areas can result in poor seal performance and frequent costly repairs. Figures 17 and 18 [9] show some of the aforementioned areas.

Although inadequate for complete mechanical seal design, the following may provide some useful starting points:

- For normal hydrocarbon service, silicon carbide (S.C.) against carbon graphite seal faces give good service. Two hard faces such as S.C. and tungsten carbide may avoid wear in slurry service. The type of binder used to manufacture these seal face materials is also important as it can often be harder than the base material.

- Secondary seals. Avoid the use of an O-ring material, which may take a set, for the dynamic secondary seal. (Note: More recent O-ring materials for high temperature application are said to have overcome this problem, although this remains an area of uncertainty. Consult your local O-ring supplier.)

- Auxiliary seal design, when required, must be adequate to limit leakage to a reasonable amount on primary seal failure. A floating carbon bushing, spring-loaded axially, is usually adequate.

- Where *dual seals* are required, they must be *double seals* where no pumped fluid leakage is permissible, and are preferred in vacuum service. An extremely dirty service will benefit from the use of double seals. *Tandem seals* are preferred otherwise. Both tandem and double seals use a barrier fluid between the seals. In double seals, the fluid is pressurized to greater than the pumped fluid pressure. In tandem seals, the fluid is generally a few feet head above atmospheric pressure. Seal pots (reservoirs) for double and tandem seals often require auxiliary cooling. These barrier fluids must be compatible with the pumped fluid, particularly in double seal applications where leakage into the fluid will result on seal failure.

- Stationary metal bellows seals are the overall preferred type, but caution is recommended at stuffingbox pressures above 150 psig. They accommodate a greater degree of misalignment. Bellows seals in general are preferred for high temperature applications. Pusher seals are sometimes preferred in light hydrocarbon service, where low lubricity can cause problems with some metal bellows seals. Balance ratio is important in light hydrocarbon service to minimize heat generation at the seal faces. The correct selection of seal type is critical to reliable service and seal life.

- Where discharge flush is used, it must not come off the outside of a bend in dirty or slurry service. This will increase the percentage of particulate in the flush.

- Vertical seals should have vents.

- Quench is required where pumped material will form solids on the atmospheric side of a seal. *Normal* leakage from a mechanical seal can cause coking in many hydrocarbon services.

- Seal flush cooling is required where the projected temperature margin between vapor temperature at the seal faces and the flush temperature is below a minimum of 25°F. Throat bushing clearance may be important to increase stuffing box pressure and increase this temperature margin.

- Sleeve mounted cartridge seal design should be considered to simplify seal maintenance. The sleeve also serves to protect the shaft.

Only a brief overview of mechanical seals is included here and this topic requires separate detailed attention to do justice to this very critical area in pump specification and selection.

#### Materials

Material specification should be made by the purchaser to avoid uneven bidding, utilizing API 610-Table F-1. Consultation

with a metallurgist will be necessary in special cases where corrosive or abrasive liquids are being pumped. Hard coating or the use of wear plates may apply in these cases. Appendix F of API 610, Table F-1, will generally set sufficient guidelines for the large majority of applications. API 610-Table E-1 allows a detailed check of materials quoted.

#### *Auxiliary Piping*

Mechanical seal auxiliary piping must be adequate to cover all seal flush, flush cooling, filtration, quench and vent requirements. It must also include the necessary vessels and circulation facilities for tandem or double seals. Where the seal flush must be cooled, a fresh cooling water supply must be routed; this is the user's responsibility and is not generally included in the pump specification.

The type of piping, gusseting requirements, etc., must be clearly defined by quoting the appropriate standards—generally these are covered in the API 610 standard with internal company standards used to qualify piping support requirements.

Piping for lube oil and mechanical seals should normally be supplied and fully installed by the pump manufacturer.

For mechanical seal piping properly run and well supported stainless steel tubing will facilitate easier maintenance than hard piping. Dangerous or flammable fluids, however, may dictate hard piping.

#### *Lubrication and Bearings*

The majority of centrifugal process pumps will be fitted with rolling element bearings with oil lubrication from an oil sump in the bearing housing, utilizing shaft oil rings. Oil level indication is mandatory with such installations, and it is recommended that a bearing housing sump drain pet cock (with plug to prevent loss of oil if left or knocked open accidentally) be fitted to permit regular sampling preventive maintenance checks for the presence of water or other contaminants in the oil.

Wet sump oil mist and dry sump oil mist are other excellent methods of lubrication where a large number of pumps are installed in proximity. Dry sump systems do not require oil rings. Venting arrangements for such oil mist systems must be clearly defined in consultation with the oil mist system supplier.

Special bearing housing seals may provide added protection when pumps are turbine driven and leaking steam can cause water contamination. Such seals can dynamically resist the ingress of steam to the bearing housing. However, difficulty may be experienced in preventing moisture buildup when the shaft is stationary. An alternative method of combating such water contamination is to provide a low pressure (one to two psig) air supply to the housing. This does require a PRV and/or restriction orifice, but has been proven to be very effective.

On vertical inline pumps, the main support bearings are in the motor with only a guide sleeve in the pump. In all cases, top mounted thrust bearings should be specified as mandatory and for horsepower ratings above 100 HP oil lubrication should be specified. Thrust bearing failures, where lower mounted thrust bearings have been installed, have caused numerous fires in hydrocarbon service due to related seal leakage striking the hot bearing housing.

Bearings of the 5000 series which have filler notches can lead to early failure due to possible mounting errors. The 7000 series is preferred for thrust bearings. While there is some debate as to the optimum contact angle, a 40 degree angle is often preferred for this service [12]. Duplex bearings mounted back-to-back with a light preload will maintain rotor axial position and provide a firm shaft support to minimize deflection. Various cage materials are being provided today and care must be taken to ensure the correct bearings are specified with the desired cage material.

Request a bearing L-10 life of 40,000 hr minimum at bearing loads encountered when operating at any point between minimum continuous stable flow and rated flow. This bearing life is generally attainable with today's bearings, although it exceeds API 610 requirements.

#### *Inspection and Test*

A routine unwitnessed pump performance test in the vendor's shop is a minimum requirement before shipment. Such a test should be performed according to "ASME Performance Test Code PTC 8.2 - Centrifugal Pumps" or "The Hydraulic Institute Standards-Centrifugal Pump Section." Where a pump may be called to operate under low NPSHA or much above its BEP, a witnessed suppression test (for NPSHR) and/or witnessed performance test should be included in the specification. For such tests, it is recommended that a one foot head drop instead of a three foot head drop be used to determine the acceptable flow for a specific NPSH. Such tests increase the cost of the pump package, and generally are only called for in critical applications. Other mechanical areas such as bearings, seals, vibration levels and hydrostatic testing can also be checked during witnessed shop tests.

Where exotic materials are used, a certificate of compliance furnished by an independent body should be requested.

If the pump is to be shop tested with its specified motor (as opposed to a shop motor), on its baseplate, checks for construction, alignment, and adequate support should be included where shop witnessed tests are specified.

#### *Vertical Pump Details*

Special bearing requirements for vertical inline pumps were covered under *Lubrication and Bearings*.

Canned vertical pumps must have their NPSHA and differential head based on the centerline of the suction and discharge nozzles as the canned (or deepwell) pumps meet the NPSH requirements by adjusting the depth of the can. The internal bushings of vertical canned pumps are subject to wear and their material must be reviewed for compatibility with the pumped fluid. A flush supply to these bushings may be necessary, particularly if abrasives are present. This type of pump is not recommended for slurries.

These pumps do not tolerate dry running and some form of low level alarm/cutout may save extensive repairs which are often costly.

#### *Weight*

The weight of the various components may do little to assist in hydraulic analysis, but may serve as a guide to the strength (or sturdiness) of casings and baseplates.

#### *Additional Information*

The one and one-half lines offered on the API 610 pump data sheet should not be taken as representative of the amount of additional information which should be given to the vendors. Many of the items highlighted as important in previous sections (*Liquid Specification* through *Vertical Pump Details*) are not represented in the data sheet and must be written in a qualifying attachment.

Inhouse standards governing exceptions to the API 610 standard must be listed. All other standards referred to, including special inhouse standards, must be tabulated (the vendor must be in receipt of these standards). Special requirements must be clearly presented as part of the specification. Typical information might include:

- criteria for determining minimum stable flow. Vendor may be asked to quote minimum flow accordingly.
- the efficiency cost incentive in terms of \$/hp.

- bearing L-10 life requirements which exceed the API 610 standard.
- volute tip to impeller periphery minimum clearance for high head pumps or pumps with a stage head greater than 650 ft.
  - mechanical seal auxiliary seal type preferred.
  - bearing housing seal type preferred.
  - definition of noise level limits.
  - material mill reports required.
  - special welding and attachment procedures for appurtenances.
    - a table listing the percentage of time the pump is expected to operate at various flows (minimum, normal, maximum).
    - wear plate or hard coating requirements.
    - additional rust protection or water protection if outdoor storage is planned prior to installation.

## BID REQUEST

A limit should be placed on the number of vendors to which requests for bid are sent. The number of vendors bidding should be in the range of three to five. The idea of a single source supplier with customized quality standards sounds ideal, but often one vendor's pump range is insufficient to cover hydraulic requirements, efficiently, in all cases. Where a specified pump is obviously in the easily supplied range for most vendors, three, at the most four, vendors should be requested to bid. This number may be increased to five or six vendors where more difficulty is expected in meeting the specified requirements.

Standardization can reduce spare parts inventories and vendors who have supplied similar sized pumps for your plant should be included on the bid list if their pumps have given satisfactory service.

All documentation and associated standards must be submitted with the bid. Standards which will not be used, e.g., steam turbine standards when a motor drive is required, should be removed from the list. Try to make the vendor's job of bid preparation as easy as possible to ensure he reviews all relevant data. Make specific requests that vendors list all exceptions to the specification and associated standards.

Be careful not to leave vendor selection to engineering contractors who may not be familiar with your current pump inventory. Discuss this with the contractors and combine their experience with your own in arriving at a list of vendors. A contractor may have excellent experience with a vendor. Your experience with the same vendor may show poor followup with parts delivery and engineering advice when problems have been encountered.

It costs vendors time and effort to prepare a satisfactory bid package. It also costs users time and effort to review each bid. For both reasons, it is important that bid requests are sent only to those vendors whose pumps will be seriously considered if they meet the specification.

## BID REVIEW

A clear and comprehensive specification will enable price comparisons on an equal basis. Exceptions to the specifications must be weighed carefully as some exceptions will be more critical than others.

A tabulation of bids is recommended where the evaluation is broken into sections, typically:

- hydraulic performance and noise
- construction
- driver

- price

The following are typical considerations in these areas:

### *Hydraulic Performance and Noise*

- BEP flow relative to rated flow
- Specific Speed (S) and Suction Specific Speed (Ss)
- NPSHR vs NPSHA (for rated and maximum flow expected)
- head rise from rated flow to shut off
- efficiency at normal flow
- minimum continuous flow (turndown)
- noise levels
- maximum hydraulic power possible

### *Construction*

- coupling type
- mechanical seal offered
- single or double volute
- bearings' type, L-10 life and bearing housing design
- material compliance
- pump type (vertical inline, horizontal, single/double suction, etc.)
  - impeller size offered versus minimum and maximum impeller diameter
  - lubrication type
  - flange ratings
  - maximum possible thrust load
  - baseplate grouting facilities

### *Driver*

#### *Steam Turbine*

- limiting horsepower at inlet steam conditions
- governor type
- trip and throttle valve assembly
- steam seals
- type - manufacturer

#### *Motor*

- horsepower rating
- type of enclosure
- service factor
- voltage and speed
- Frame

#### *Common Driver Comparisons*

- Bearings—type, lubrication, L-10 life
- Efficiency
- Thrust capacity, for vertical inline pump

### *Price*

- Price of pump
- Price of motor or turbine
- Price of mechanical seal
- Price of inspection and/or testing
- Extras for special preparations

The previous considerations are offered as basic guidelines for bid comparisons and each particular application will demand different areas of emphasis or additional items of comparison.

Where one pump has characteristics noticeably different from the others, these should be looked at more closely. Some areas where a marked difference will signal a closer look are:

- pump weight.

- NPSHR.
- bearing L-10 life.
- impeller diameter.

When bid comparisons are made, one pump may not stand out clearly from the rest as the obvious selection. One may provide excellent minimum flow capabilities, while another may require less NPSH. The positions of the BEP point relative to normal and noted points will vary. The margin between rated impeller and maximum impeller will vary. These and other comparisons must be given the correct weighting when assessing bids. Once again, the system analysis conducted at the outset of the specification process will provide the weighting required for each comparison.

A spreadsheet approach utilizing personal computer software is a convenient and accurate method of bid comparison. A typical software package would allow automatic calculation and display of such items as specific speed and suction specific speed and may even be tailored to project a calculated minimum continuous stable flow based on selected criteria. A handwritten tabulation, while taking a little longer to prepare, will provide an equally satisfactory bid comparison if based on the same criteria. An example of a typical personal computer spreadsheet bid tabulation is shown in Table 1.

PUMP SELECTION

The following are some guidelines in areas of major importance:

- The NPSHA should be at least five feet more than the NPSHR at maximum flow. This differential is generally less critical in heavy hydrocarbon service. A three feet net NPSH (NPSHA-NPSHR) should be viewed as a minimum. Where net NPSH is below three ft, an alternative pump is recommended. If no suitable alternative is available, a witnessed suppression (NPSH) test should be included in the contract. (Refer to the discussion of NPSH section *Pump Boundary Conditions* for a more detailed approach to NPSHA and NPSHR). Check the NPSHR curve. Curves which rise rapidly after the BEP point will limit flow increase. A flat NPSHR curve is best.

- For performance evaluation, ensure that any viscosity corrections required have been made. Review of viscosity corrections is permitted from Figure 17 (Hydraulic Institute). For most applications, corrections will not be necessary.

- Compare calculated minimum flows based on suction specific speed and do not accept the vendor's quoted minimums without review.

- Ensure that driver horsepower is greater than BHP required at maximum possible flow. A pump horsepower curve which reaches a maximum close to BEP and rounds over is preferred over a steadily rising curve.

Table 1. Bid Review Spread Sheet.

TABLE #1

PUMP PROPOSAL COMPARISON SHEET		DATED: REPORTED BY: SHEET 1 OF 2	
CLIENT: PROJECT: PUMP:			
SERVICE AND OPERATING CONDITIONS			
RATED FLOW (USGPM): NORMAL FLOW (USGPM): FLUID DESIGN TEMP. : SPECIFIC GRAVITY : VISCOSITY : VAPOUR PRESSURE :		DISCHARGE PRESSURE : SUCT PRESS MAX/RATED DIFFERENTIAL PRESS. : DIFFERENTIAL HEAD : NPSH AVAILABLE : HYDRAULIC POWER :	
SUPPLIERS --->			
PUMP model size type			
PERFORMANCE ----- EFFICIENCY @ DES FLOW (%) BEST EFFICIENCY (%) BEP (USGPM) MIN CONT FLOW THERMAL/STABLE USGPM MIN. FLOW % OF BEP RATED PUMP SPEED (RPM) SPECIFIC SPEED (RPM) SUCT. SP. SPEED, MAX. IMP. MAX. HEAD RATED IMPELLER(FT) SHUTOFF HEAD % OF RATED HEAD BHP @ RATED FLOW BHP @ EDC EDC BHP % OF RATED HP 110% BHP @ RATED FLOW NPSHR @ RATED FLOW NPSHR @ BEP FLOW, MAX IMP. NOISE LEVEL DBA (MOTOR/PUMP/COMBINED)			
MECHANICAL SEAL ----- MANUFACTURER MODEL/TYPE SEAL CLASS SEAL FLUSH PLAN SEAL FLUSH PIPING MAT.			
CONSTRUCTION ----- SUCTION SIZE/FLG RATING DISCHARGE SIZE/FLG RATING PUMP WEIGHT LBS MOTOR WEIGHT LBS TOTAL WEIGHT LBS CASE MAT'L CASE WEAR RING MAT'L IMPELLER TYPE IMPELLER MAT'L IMP. SIZE (MIN/RATED/MAX) SHAFT MATERIAL SLEEVE MATERIAL BRG. TYPE (RADIAL/THRUST) L-10 LIFE THRUST BRG. LOCATION DRAIN SIZE			

TABLE #1 CONTINUED

PUMP PROPOSAL COMPARISON SHEET		DATED: REPORTED BY: SHEET 2 OF 2	
CLIENT: PROJECT: PUMP:			
SUPPLIERS --->			
DRIVER ----- MANUFACTURER VOLTAGE TYPE HORSEPOWER (HP) SPEED (RPM) FRAME LUBRICATION HEATER INSULATION			
TESTING ----- PERFORMANCE HYDROSTATIC			
PRICE ----- PUMP SEAL & COUPLING MOTOR CERT. PERFORMANCE TEST MOTOR HEATER COST OF PAYMENTS FREIGHT			
TOTAL PRICE			
DELIVERY (WEEKS)			
COMMENTS			

- Impeller diameter should not be maximum for the pump.
  - A horsepower (hp) debit should be applied based on zero debit for the most efficient pump at rated flow. All other pumps will be debited based on the differential between their BHP at rated and the most efficient pump. The debit per horsepower should be based on power costs, the expected life and the percentage DCF return on investment.
  - Check mechanical seal compliance with all details in the seal data sheet. Confirm that the seal vendor is on the listing provided.
  - Confirm that the price includes the net price, freight, duty, tax, etc.
  - For cost comparisons, be sure to include the horsepower debit. (The hp debit must be halved where the pump is spared.) This is the *evaluated cost*.
  - Confirm that the pump head capacity curve is steadily rising over the expected flow range.
  - Compare service with similar pumps installed in your plant.
  - Check mechanical construction details for compliance; e.g. pressure ratings, bearing type, L-10 life and type of lubrication. Confirm that the coupling is fail safe. Check to be sure that the bearing housing design can withstand severe radial and axial loads (is of robust construction).
- If no appreciable deficiencies exist and little difference exists in the hydraulic performance, the pump with the lowest evaluated cost (hp debit included) should be selected. This is

often not the case, and correct prioritizing is usually necessary to arrive at the best selection.

A pump with a good hydraulic fit will quickly repay a marginal extra cost through reduced maintenance costs.

The selection process must always bear in mind the needs of the process and must continually draw on the criteria defined during the early process of system analysis.

**CONCLUSION**

A clear understanding of the full spectrum of process requirements is a necessary first step in the selection of a centrifugal pump which is to give reliable, satisfactory service. Omission of process system's analysis can result in many mismatches between the purchased pump's performance and the process requirements, poor reliability and higher than normal maintenance costs.

**NOMENCLATURE**

- BEP Best Efficiency Point
- S Specific Speed
- S<sub>s</sub> Suction Specific Speed
- NPSHA Net Positive Suction Head Available (feet)
- NPSHR Net Positive Suction Head Required (feet)
- N Speed in Revolutions per Minute
- Q Pump Flow (USGPM)
- H Head Generated per Impeller or Stage (feet)
- HP Horsepower
- DCF Discounted Cash Flow
- SG Specific Gravity

*Subscripts:*

- r Rated Flow (USGPM)
- n Normal Flow (USGPM)
- m Minimum Flow (USGPM)
- bep Best Efficiency Point

$$S = \frac{N \sqrt{Q_{bep}}}{H_{bep}^{0.75}}$$

$$S_s = \frac{N \sqrt{Q_{bep}}}{(NPSHR_{bep})^{0.75}}$$

**REFERENCES**

1. Ross, R. R., "Theoretical Prediction of Net Positive Suction Head Required (NPSHR) for Cavitation Free Operation of Centrifugal Pumps" United Centrifugal Pumps publication, San Jose, California.
2. Fraser, W. H., "Flow Recirculation in Centrifugal Pumps," *Proceedings of the Tenth Turbomachinery Symposium*, Turbomachinery Laboratories, Department of Mechanical Engineering, Texas A&M University, College Station, Texas (1981).
3. Ingram, J. H., "Pump Reliability—Where Do You Start," 37th Petroleum Mechanical Engineering Workshop and Conference, Dallas, Texas, pp. 219-223 (June 1981).

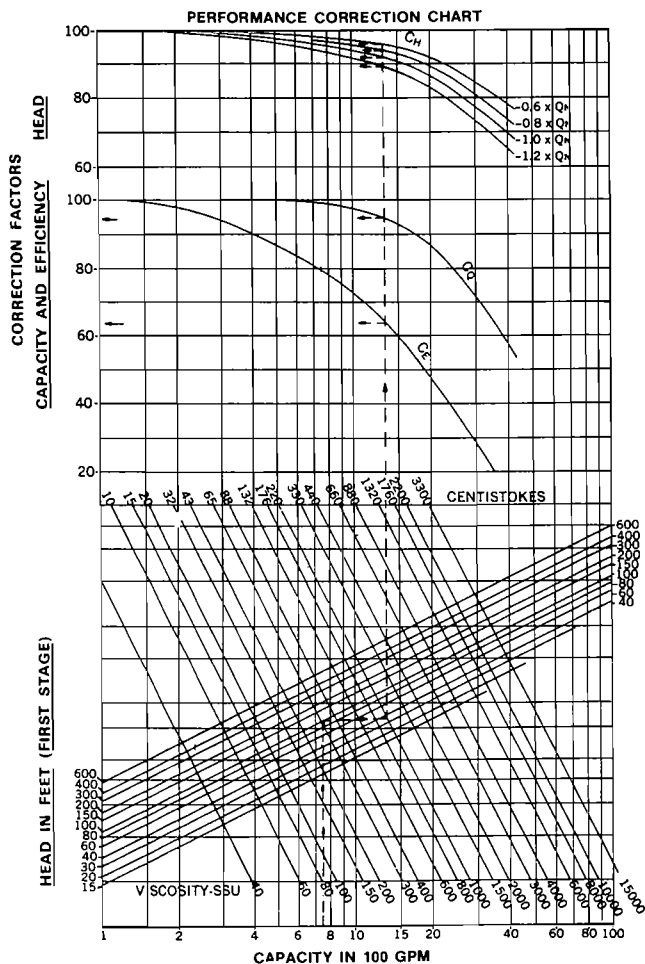

Figure 19. Performance Correction Chart for Viscosity.

4. Bloch, H. P., "Mechanical Reliability Review of Centrifugal Pumps for Petrochemical Services," presented at the ASME Failure Prevention and Reliability Conference, Hartford, Connecticut (September 1981).
5. Nelson, W. E., "Pump Curves Can Be Deceptive," presented at the Refinery and Petrochemical Plant Maintenance Conference, San Antonio, Texas (January 1980).
6. Doolin, J. H., "Judge Relative Cavitation Peril with Aid of these Eight Factors," *Power* (October 1986).
7. Palgrave, R., and Cooper, P., "Visual Studies of Cavitation in Pumping Machinery," *Proceedings of the Third International Pump Symposium*, Turbomachinery Laboratories, Department of Mechanical Engineering, Texas A&M University, College Station, Texas (1986).
8. Hallam, L., "Centrifugal Pumps: Which Suction Specific Speeds Are Acceptable?," 37th ASME Workshop and Conference, Dallas, Texas (September 1981).
9. Moore, J. K., and Glassner, W. V., "Metal Bellows Seals for Services over 400°F," Borg Warner Industrial Products, Inc. publication, Temecula, California.
10. Gopalakrishnan, S., "Minimum Flow Criteria," Pacific Energy Association Meeting in Irvine, California (October 1986).
11. Neerken, Richard F., "Progress in Pumps," *Chemical Engineering* (September, 1987).
12. Nelson, W. E., "Maintenance and Troubleshooting of Single Stage Pumps," *Proceedings of the First International Pump Symposium*, Turbomachinery Laboratories, Department of Mechanical Engineering, Texas A&M University, College Station, Texas, pp. 78-80 (1984).
13. Sloteman, D. P., Cooper, P., and Dussord, J. L., "Control of Backflow at the Inlets of Centrifugal Pumps and Inducers," *Proceedings of the First International Pump Symposium*, Turbomachinery Laboratories, Department of Mechanical Engineering, Texas A&M University, College Station, Texas, pp. 9-22 (1984).