

Improving Reliability Of Canned Motor Pumps in Refrigeration Service

King J. Molder

McKinley Climatic Laboratory Eglin AFB, FL

S. Dennis Fegan

Hermetic Pumps Inc. Humble, TX

24th International Pump Users Symposium

Outline

- ❖ McKinley Climatic Laboratory
- ❖ Pump History
- ❖ System Information
- ❖ New Pump Installation & Operation
- ❖ Current Status
- ❖ Summary

McKinley Climatic Laboratory

- ❖ Conceived during World War II and completed in 1947.
- ❖ The site provides facilities for all-weather testing of all types of aircraft, vehicles, shelters, and support equipment to ensure their function regardless of climatic conditions.
- ❖ The laboratory can recreate nearly every weather condition that exists on Earth with temperatures ranging from minus -65°F to 165°F .
- ❖ Projects have advanced only climatic simulation and testing but also concepts for refrigeration and insulation, dedicated instrumentation for evaluating turbojet performance, and surveillance and control systems.

McKinley Climatic Laboratory



Main Chamber



Plant Buildings

McKinley Climatic Laboratory



Solar Test



Snow Test

Pump History

- ❖ Existing pumps were installed in 1999 and “guaranteed” to operate for 40,000 hours between overhauls.
- ❖ Pump operating life never exceeded 1500 hours in spite of repeated attempts to identify the problems by both the manufacturer and the laboratory.
- ❖ Failure of the existing pumps was caused by excessive bearing wear.
- ❖ Refrigerant was observed leaking from the motor conduit box, requiring an immediate shutdown of the pump.
- ❖ R-22 releases are regulated by the Clean Air Act and are subject to substantial reporting requirements under the Act.

System Information

- ❖ The system is similar in design to other refrigeration systems but on a larger scale.
- ❖ Three units supply two plenum coils each for a total of six refrigerant pumps.
- ❖ The nameplate capacity of the three installed units is 990 tons at a refrigerant temperature of -105°F .
- ❖ The operation is unique because the system is required to operate between $+40^{\circ}$ and -105°F and has to be able to change temperatures in a matter of minutes.

System Information

- ❖ The pumps handle R-22 refrigerant which is used to control chamber temperature.
- ❖ In other system configurations the R-22 is also used to cool both calcium chloride and R-30 (methylene chloride) utilizing large heat exchangers.
- ❖ This allows the medium to be stored in large insulated tanks for future use during the various testing programs.
- ❖ This system allows extended testing times, far beyond the installed nameplate capacity of the refrigeration plant.
- ❖ The chilled fluids are used to cool air supplied to the chamber at the same rate as engine exhaust is removed from the chamber.

Pump Specifications

- ❖ All stainless steel construction canned motor pump
- ❖ Suitable for handling R-22 (Chlorodifluoromethane) between -105°F and $+104^{\circ}\text{F}$
- ❖ Sized to deliver 750 US gpm at a total developed head of 100 feet with an NPSHA of 6.6 feet
- ❖ Synchronous motor speed shall not exceed 1800 rpm
- ❖ Shall be provided with an axial bearing wear monitor that also indicates the motor rotation.
- ❖ Bearing wear monitor shall be capable of being replaced without shutting down the pump or motor
- ❖ Bearing wear monitor shall be capable of a 4-20 mA output for the remote indication of axial rotor position

New Pump Installation & Operation

- ❖ In 2005 new pumps were installed with:
 - All stainless steel construction
 - Bearing wear monitor
 - Rotation indication
 - Hydrodynamic bearings
 - Auxiliary impellers to return cooling flow to the pump discharge
 - Positive thrust balance control
 - Hermetically sealed motor
 - External piping to insure proper venting

New Pump Installation & Operation

External piping to insure proper venting

Hermetically sealed motor and conduit box

Positive thrust balance control

Bearing wear /shaft position monitor

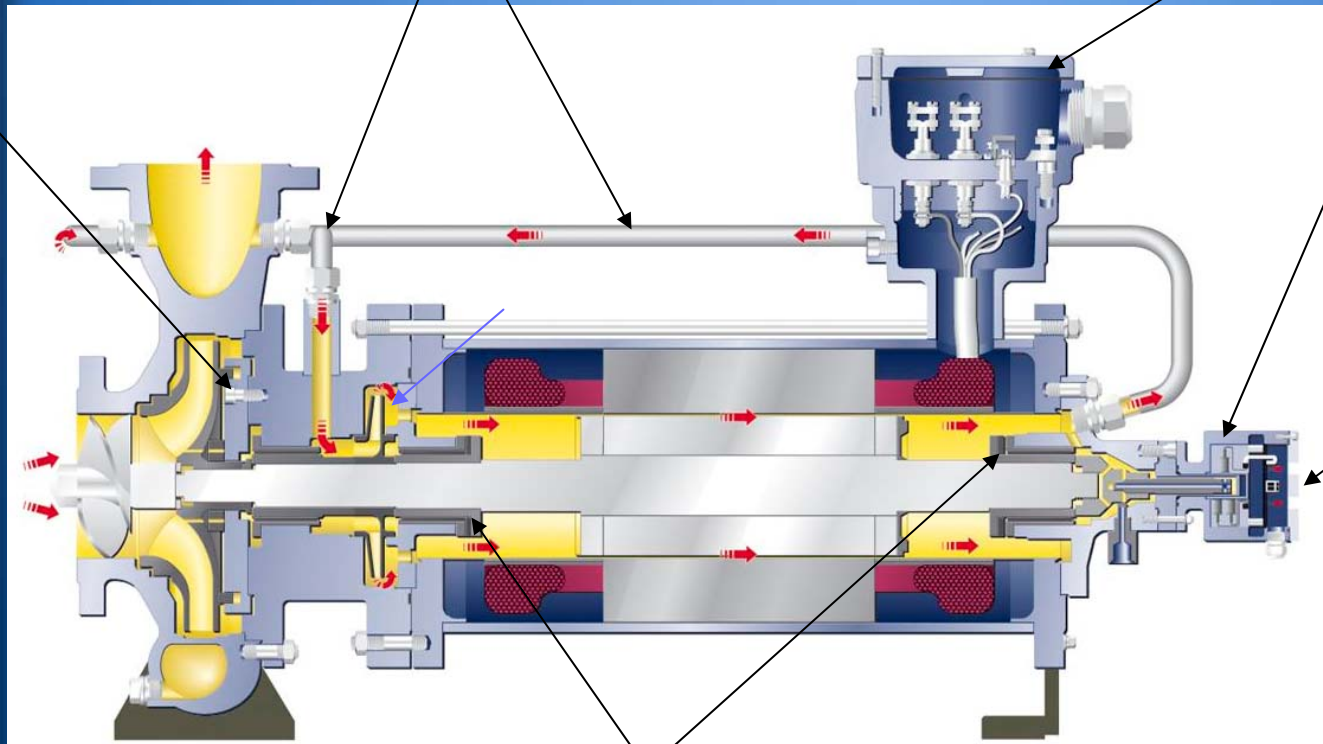

Rotation indicator

Hydrodynamic bearings

Data Screen Example

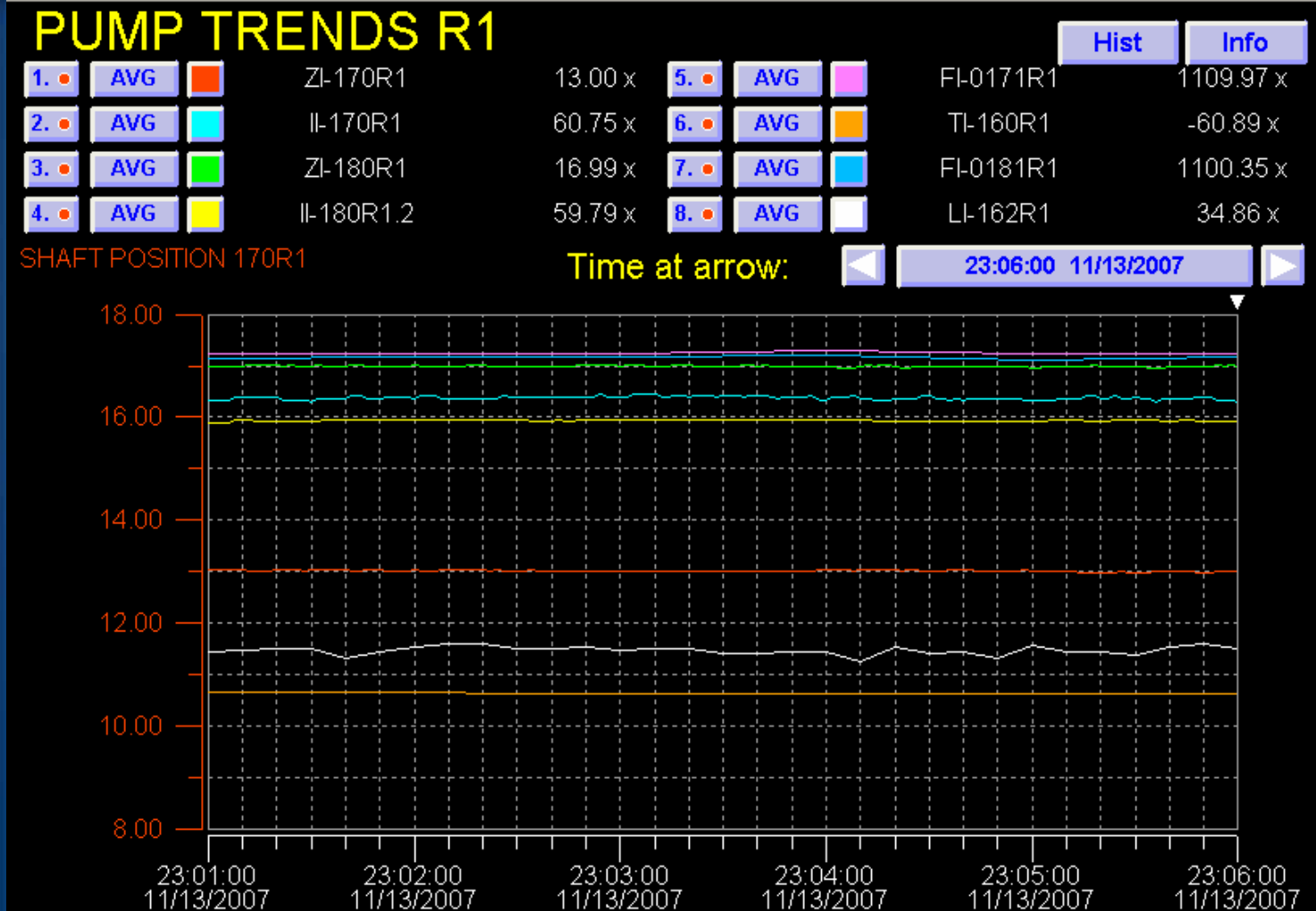

New Pump Installation & Operation

- ❖ Shortly after commissioning of the new pumps the bearing wear monitors showed that the units were not thrust balancing.
- ❖ Pumps of this type do not utilize conventional type ball bearing or segmented tilting pad thrust bearings.
- ❖ “Hydraulic thrust balancing” has been utilized for years by pump designers to reduce thrust loads on conventional pumps to allow the use of smaller thrust bearings.
- ❖ However, in sealless pumps the axial thrust must be controlled to less than 100 pounds of force in both directions. This presents a serious challenge to the designer since these machines handle a broad range of fluids.

New Pump Installation & Operation

- ❖ The initial axial thrust unbalance caused the rotor to move toward the front of the pump which is not as desirable as movement to the rear.
- ❖ The rear movement is more desirable as it allows the double rear wear rings on the back of the impeller to control the pressure behind the impeller.
- ❖ Several design changes were initiated to change the direction of the axial thrust including reducing the clearance of the double wear rings and adding baffles in front of the auxiliary impeller.

Factors That Affect Thrust Balance

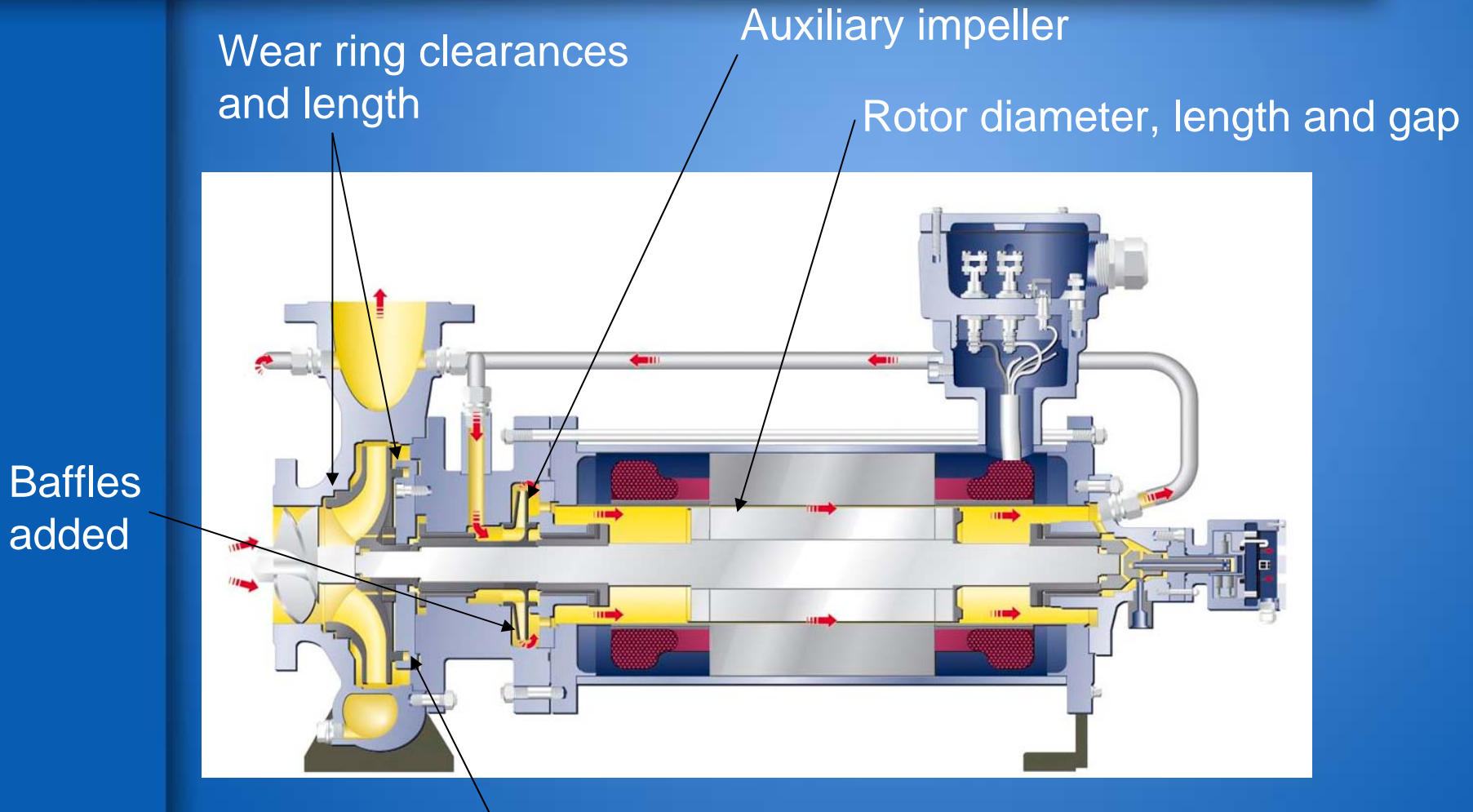

Double wear ring to control pressure behind the impeller and clearances reduced to produce rear thrust

New Pump Installation & Operation

- ❖ These modifications did reverse the direction of the axial thrust but did not eliminate the intermittent unstable operation.
- ❖ Thousands of data points were generated and studied without revealing any clues as to the root cause of the problem.
- ❖ The bearing wear monitor allowed the units to be removed before there was significant damage; the efforts to remove and replace the units were considerable.
- ❖ The data seemed to indicate that the operating temperature was a factor in upsetting the axial thrust but the data was not consistent and no trends could be established.

New Pump Installation & Operation

- ❖ This type of instability is typical of vapor being present in the motor section.
- ❖ The construction of the suction vessels was investigated and it was discovered that vortex breakers were not installed.
- ❖ A project was initiated to install vortex breakers in at least one of the three vessels to see if the problem could be corrected.
- ❖ The modification was made but no difference in the operation could be observed.
- ❖ The design point was 750 gpm but the test data indicated that flows in excess of 1000 gpm should be possible

New Pump Installation & Operation

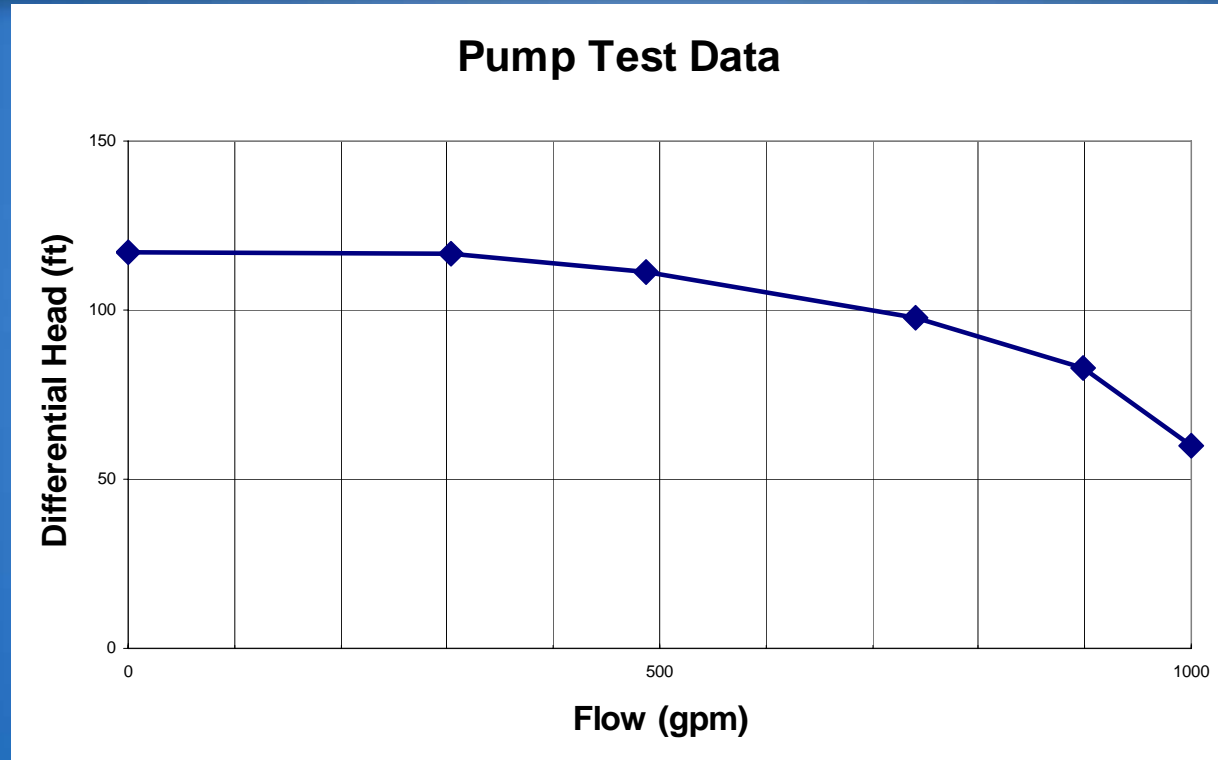

- ❖ Due to the axial thrust problem the manufacturer requested that the pumps not be operated above the 750 gpm design point
- ❖ The facility flow meters consistently indicated a lower flow rate than the values shown by checking the motor current draw.

New Pump Installation & Operation

- ❖ In February 2007 during a pump disassembly a liquid with a green tint was observed in the pump case.
- ❖ It was determined that this liquid was calcium chloride solution. The green tint was recognized by facility personnel and results from copper being stripped from coils by the brine.
- ❖ The presence of calcium chloride indicated that the heat exchanger(s) were leaking allowing contamination of the system and causing ice to form in the R-22 system.
- ❖ It was discovered that the temperature on one of the heat exchangers was allowed to drop below the minimum, allowing one tube to rupture.
- ❖ Repairs proved to be unsuccessful and this heat exchanger had to be replaced.

New Pump Installation & Operation

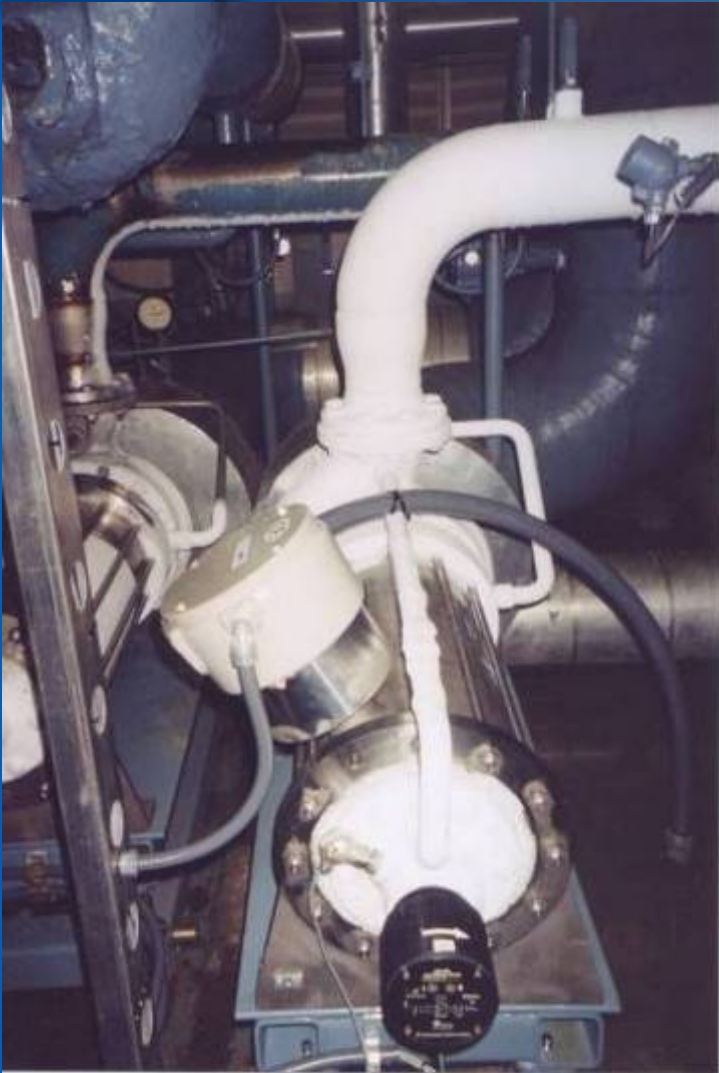

- ❖ Root cause of the problem was ice in the system
- ❖ Ice was centrifuged in the pump case and pumped directly into the motor
- ❖ Ice upset the hydraulic balance of the pumps.
- ❖ Pumps are performing well and are allowing flow rates in excess of 1000 gpm depending on system head.

Pump in operation

Summary

- ❖ Pumps in refrigeration service require special review, especially in services that require frequent temperature changes.
- ❖ Instrumentation, especially that monitor shaft position is critical in sealless pumps.
- ❖ Constant monitoring is essential to detect problems early.