

NEW DEVELOPED MULTISTAGE VARIABLE SPEED DRIVE (MSVD) OF HIGH ECONOMY, FOR THE SPEED CONTROL OF PUMPS WITH POWERS UP TO 40,000 HP

by

Walter Rappold

Chief Project Engineer

Voith Turbo GmbH and Company KG

Crailsheim, West Germany



Walter Rappold is Chief Project Engineer of the Variable Speed Drives Division at Voith Turbo GmbH and Company KG, in Crailsheim, West Germany. As Sales Manager, he is responsible for worldwide planning and handling of applications using variable speed and geared variable speed turbo couplings and multistage variable drives.

After completing his Mechanical Engineering studies in 1959, Mr. Rappold worked in steel construction and engineering, before joining Voith in 1970.

ABSTRACT

The multistage variable drive, called MSVD, the latest development of a hydrodynamic mechanical drive system is presented.

The special characteristics are high efficiency, excellent reliability, and availability, which are typical features for hydrodynamic drives.

The drive is described in detail, the physical features are presented and the measured values of the prototype, type variants, application possibilities, fields of application and references are shown.

INTRODUCTION

Essential for planning and functioning of process systems in industrial plants and installations are certainly the following main criteria which are also used to evaluate units used as main drives in these plants.

- Competitive conditions, which means low capital investment
- Economic operation, thus minimizing operating cost
- High reliability, i.e. highest availability over typical operating periods of 25 years or longer.

For decades, variable speed and geared variable speed turbo couplings are used worldwide to drive (i.e., in conventional as well as in nuclear power plants) rotating machinery used to control the functioning of such plants. These driven machines are boiler feed pumps, boiler fans, coal crushers, coal conveyors, district heating pumps, cooling water and condensate pumps. An increasing number of turbo compressors and reciprocating compressors are driven using these units calculated and made to API 613 and API 614.

A challenge for skilled and successful fluid and mechanical engineers was the increasing importance given to the efficiency of main components of such speed turbo coupling, working according to the hydrodynamic principle (slip control). As a result, a

hydrodynamic-mechanical combination was developed with an additional controlled power superposition part. The decisive feature of this combination is that two power transmission branches, driven from the same input shaft, are also driving one common output shaft.

DESCRIPTION OF THE DRIVE

Design

The new drive combines six major proven elements. The design of the MSVD can be seen in the sectional view of Figure 1.

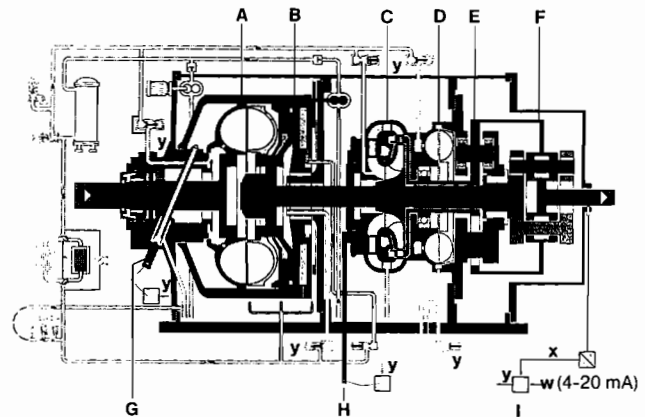

- | | |
|---------------------------------|----------------------------|
| A Variable speed turbo coupling | G Scoop tube |
| B Lock up clutch | H Guide vane |
| C Torque converter | I Multi-circuit controller |
| D Hydrodynamic brake | w Set value |
| E Planetary gear fixed | x Actual value (feedback) |
| F Planetary gear revolving | y Controller output |

Figure 1. Sectional View of the Multistage Variable Speed Drive MSVD.

The different components are:

- A Variable Speed/Variable Fill Fluid Coupling (A) with scoop tube and actuator. The position of the scoop tube (G) determines the quantity of oil in the circuit and varies output speed.
- A Hydraulically Controlled Lockup Clutch (B). When actuated, it mechanically connects the primary and secondary wheels of the fluid coupling (A), thus eliminating slip.
- A Torque Converter with Adjustable Guide Vanes and Actuator (C, H). With a constant input torque and speed, the torque converter output speed and torque can be varied by changing vane position (H).

- A *Hydrodynamic Retarder (D)*. Consists of a rotating primary wheel similar to that of the fluid coupling, however, with inclined vanes and a stator instead of the secondary or turbine wheel.

- *Planetary Gear Sets (E, F)*. Each set consists of sun wheel in the center and planetary carrier holding the planet wheel and internal tooth annulus.

- A *Microprocessor (I)*. It provides total system control, e.g. adjusts scoop tube, lockup clutch, guide vanes, solenoid valves and retarder. Also it monitors pressures, temperatures and controls oil flow to the coolers.

Principle of Function

Lower Operating Range (Range 1, Figure 2):

In this range, power is transmitted via the variable speed coupling (A) and the planetary revolving gear (F), speed regulation is effected exclusively in the rotating parts of variable speed coupling (A) by means of the scoop tube position (G). The regulating range is up to approximately 80 percent of the maximum speed. The torque converter (C) is drained and practically transmits no torque. The hydrodynamic retarder (D) is filled and brakes the planetary gear (E) down to a lower speed. Thus, the planetary revolving gear (F) has a constant gear ratio. The annulus, as superimposing part, has no effect on the gear ratio.

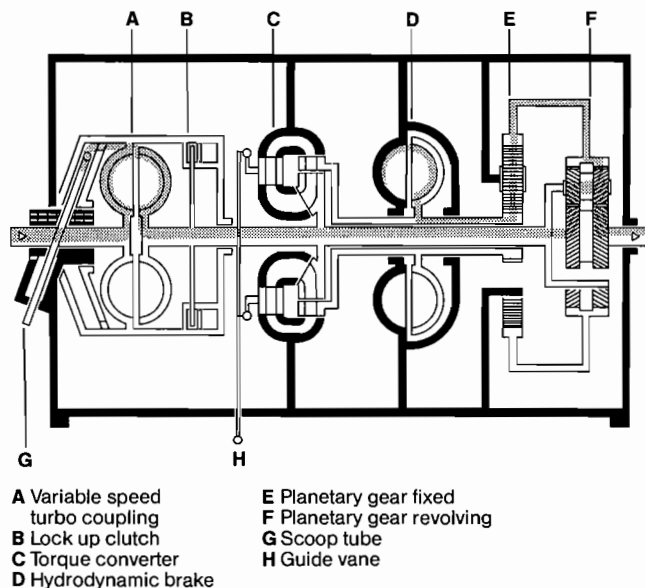

Figure 2. Power Flow in the Lower Operating Range (Range 1).

The hydrodynamic retarder (D) was selected instead of a mechanical brake, in order to keep the planetary gear (E) rotating at low speed and to avoid pitting or chatter marks in the gearbox.

Upper Operating Range (Range 2, Figure 3):

The lockup clutch (B) in the variable speed coupling (A) is clutched. Secondary and primary part are one integral part and the converter pump impeller is running with the same speed as the drive motor and coupling.

Speed regulation is effected by changing the guide vane position (H) of the torque converter (C) resulting in a change in speed of converter turbine wheel. The planetary gear revolving (F) is therefore additionally driven via the planetary gear fixed (E) resulting in a varying output speed. Thus, the operating

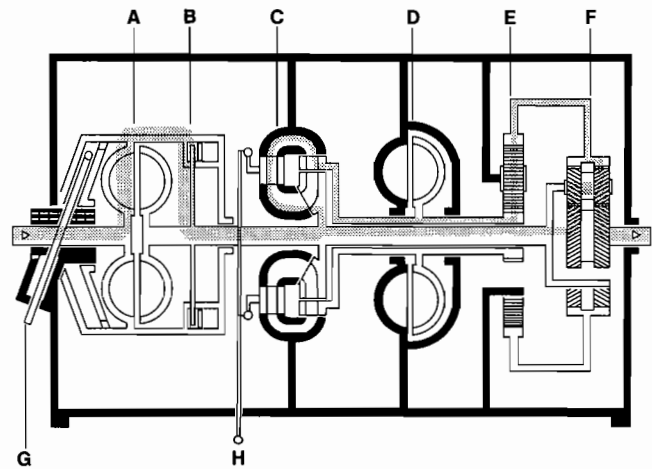

Figure 3. Power Flow in the Upper Operating Range (Range 2) (Coupling synchronized).

range between 80 percent and 100 percent output speed can be achieved. The hydrodynamic retarder (D) is drained, except for a slight oil flow intended to dissipate the ventilation heat.

The individual hydraulic components are controlled via solenoid valves. These functions are controlled and monitored via an electronic logic system (I). This logic system also has to react on external setpoint signals. The speed is measured by an inductive speed measuring device and transmitted to the logic system.

Working and lube oil is supplied by a shaft driven pump connected to the input shaft. An auxiliary electric motor driven pump connected in parallel supplies lube oil for start up and shut down for the entire drive system. It is also actuated by low oil pressure signal.

Lube oil requirements for the driving motor and the driven machine are supplied by the shaft driven pump and auxiliary pump in the MSVD oil system. This eliminates the need for a separate external supply system.

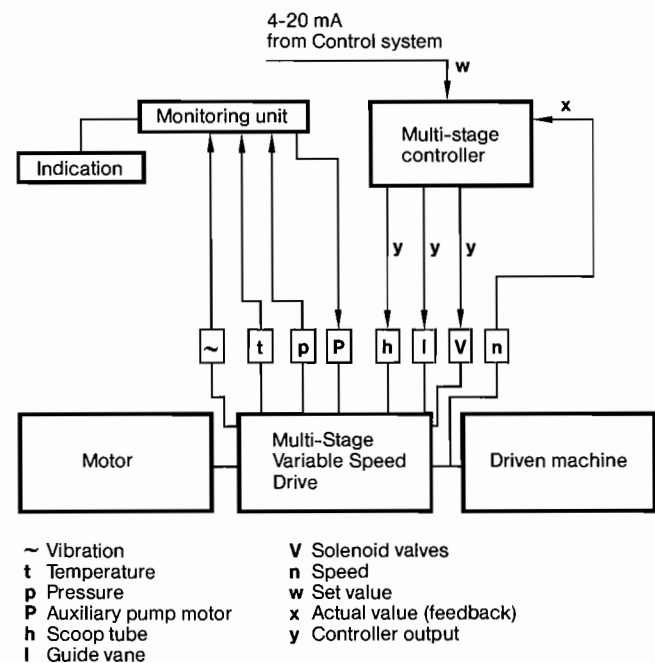

Figure 4. Monitoring and Control System.

Monitoring and Control System (Figure 4):

The control logic for the actuators and solenoid valves is incorporated in a modular microprocessor based DDC controller (direct digital control). Thus, the MSVD can be included in any control circuit simply by transmitting a standard 4-20 mA control signal. The response times can be adapted to the application. The nominal variable for runup time for the boiler feed pump for example is 10 seconds. The lockup and switch over from fluid coupling drive to the torque converter drive, which occurs at approximately 80 percent of maximum output speed, takes approximately two seconds.

Bearing and oil temperatures and oil pressures of multi stage variable drives are monitored using appropriate instruments. Analog and binary signals are to be processed by the plant control system.

Torque/Speed Characteristic of the MSVD

This diagrammatic representation (Figure 5) shows the family of characteristics of the MSVD, i.e., torque vs speed. The coupling or converter torques to be transmitted are shown as parameters as a function of scoop tube or guide vane position, respectively. It also shows a typical load curve of a driven machine with parabolic characteristic (e.g., centrifugal pump).

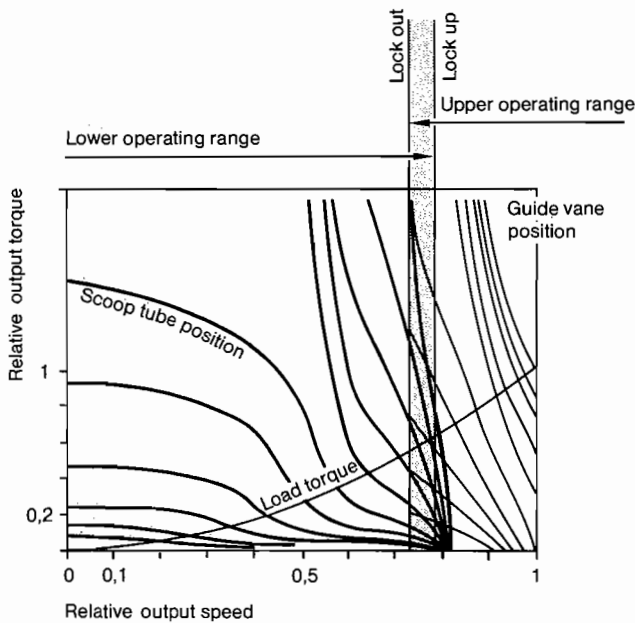

Figure 5. Torque/Speed Characteristics.

The desired output speed is, in each case, shown as intersection between coupling/converter torque and load torque. The large regulating range and the wide hysteresis loop between lower and upper operating range are clearly evident.

In the case of reverse rotation of driven machine with drive motor running, it can only occur in the coupling operating range on account of the torque characteristics curves which are not shown here and brought again to forward motion by increasing the filling. Since the torque is not reversed, the superposed drive is protected against overspeed by the retarder.

Efficiency

In Figure 6, efficiency and speed parameters of various systems are compared and plotted over load. The improvement compared to the conventional slip control is clearly evident.

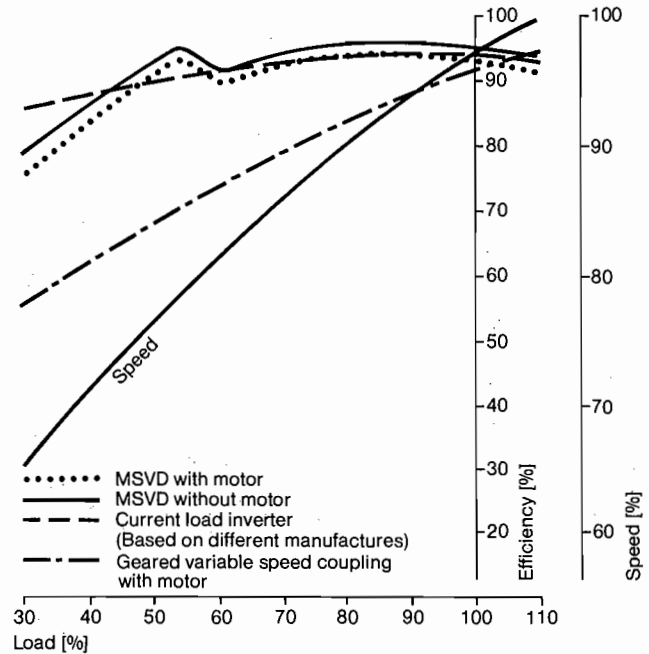

Figure 6. Efficiency of MSVD in Comparison with other Systems.

From what does the efficiency of the MSVD result? The hydraulic efficiency results from the known values of the individual components and the split power, due to the system. Thereby three main operating conditions are to be distinguished (Figure 7):

- Speed adjustment by the hydrodynamic coupling in range 1 with flexible braking of the annulus via the retarder.
- Speed adjustment by the torque converter with reverse running turbine wheel:
 - In the superposing system a negative power is transmitted to the torque converter via the reverse rotating annulus.
 - Speed adjustment by the torque converter in operating range 2 with positive power flow in the superposing system.

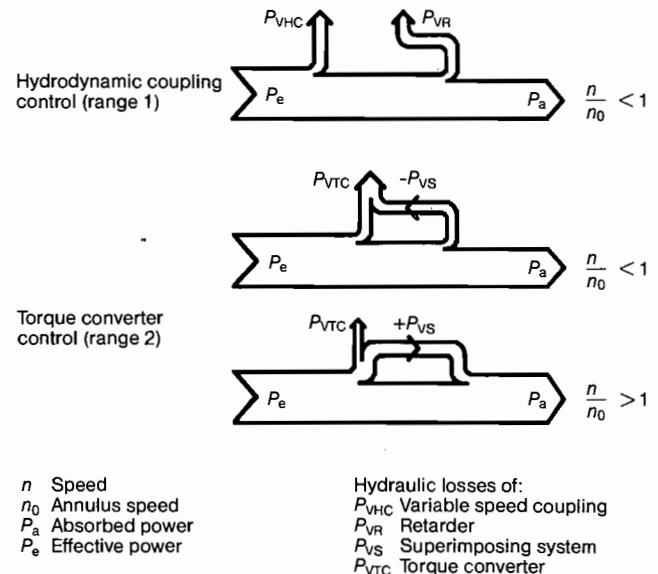

Figure 7. Power Split (Range-Dependent).

The efficiency behavior in operating range 1 is identical to the course known from the variable speed coupling. Also the retarder required to brake the annulus is a machine element subject to slip and does not influence the efficiency course with its power loss P_{vr} but only the upper change-over point and thus the highest achievable efficiency value during coupling operation.

The counter braking range of the torque converter enables a stable operation event at the annulus standstill point. However, it has an unfavorable efficiency behavior with increasing negative superimposed power. Therefore, changeover should be made as early as possible due to favorable coupling efficiency.

The efficiency behavior at superimposing operation is mainly determined by the relative torque converter speed selected and, in addition, it is influenced by the selection of the converter design and the load characteristic curve. The diagram shows that a comparable efficiency can be achieved if the various operating ranges are selected properly (Figure 8). Compared to the variable speed coupling the MSVD offers an improvement of efficiency over almost the complete speed regulating range.

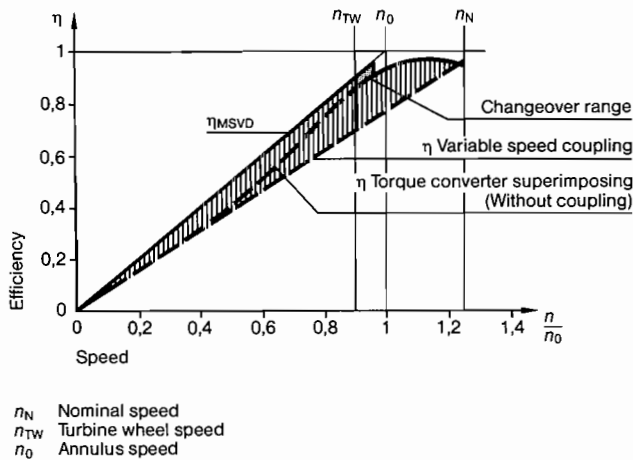

Figure 8. Hydraulic Efficiency.

At first glance, the improvement reached still seems to be insufficient, since it is limited to a comparably small speed range. However, if the system characteristic curve, the load pattern, and the unit characteristic curve of the machines to be driven are considered, then it is found that the range of the highest efficiency of the drives matches with the operating range of the machine.

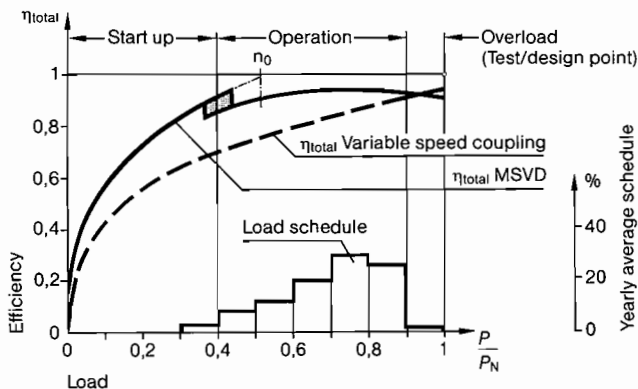

Figure 9. Total Efficiency, Load Schedule Boiler Feed Pump Drive, Peak Load Station.

When using a typical boiler feed pump drive as an example, an actual comparison between efficiency parameters of a variable speed coupling and a MSVD is possible (Figure 9).

The total efficiency of a multistage variable drive consisting of a hydraulic and mechanical efficiency is plotted over the power transmitted to the driven machine. In addition, the operating ranges common in boiler practice and the frequency distribution of the load which is representative for a medium-load coal-fired power station are shown. This enables a quick judgement of the complete drive system.

Design Criteria, Reliability and Availability

The availability has priority for the operator and therefore the goal is to design and arrange the elements for a possibly low loss power transmission with high availability and life at the same time. The noise emission and the mechanical vibration values also should be low. The dynamic requirements in the power station for reaction time, rapid starting times and speed accuracy are to be met as up to now.

The individual components will be explained on a constructed unit. The three main elements for speed variation work according to the wearfree, hydrodynamic principle. All torque transmitting components are arranged coaxially and thus they are compact and with low noise.

Every one of these elements has approved itself as individual machine in continuous operation under comparable powers and speeds and can be assumed to be known. Combinations of individual elements in the most different applications also were executed and have provable high availability values.

In spite of this still some essential points are to be explained

- The turbo coupling (in this case, arranged on the low speed side) allows for a load free drive motor start and a smooth, torsional vibration-free runup of driven machine.
- The clutch is designed as a multidisc clutch. The friction material is selected for a smooth switching. Due to the low mechanical and thermal design, wear is practically not measurable in spite of frequent switchings. The combination selected also allows elimination of temporary torque peaks.
- The torque converter is a variable speed torque converter with constant filling. The torque transmitted depends on the speed ratio and on the position of the guide vanes.
- The hydrodynamic brake consists of a stationary and of a rotating wheel with inclined blades. Therefore, the high braking torque only acts in one direction of rotation. The torque, and thus, the speed, can be controlled by varying the oil filling.

Measuring Results

A multistage variable drive as described was built as prototype for the power data of a boiler feed pump in the lower power range (Figure 10) with $P_{max} = 1285$ hp, $n_{out} = 6245$ rpm, $n_{in} = 1800$ rpm.

After a few preliminary tests which were provided especially to clarify constructional details, the actual tests were carried out. For this, a test stand design was selected which enabled the simulation of the operating behavior of a boiler feed pump regarding load characteristic curve and control dynamics.

The trial on the test stand can be divided in three major points.

Hydrodynamic Torque/Speed Characteristics of the Prototype

The family of characteristics of MSVD were proved by test field measurements (Figure 11). The empirical values are covering the characteristic curves of coupling/converter torque vs speed excellently compared to the theoretical values in Figure 5. A speed stability of plus minus 1 per mil of rated speed over

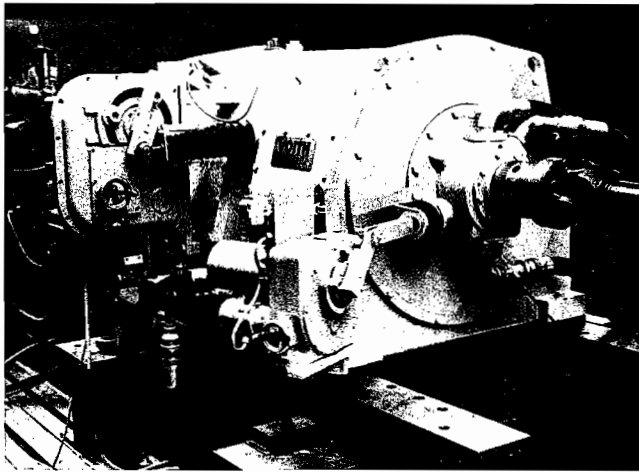
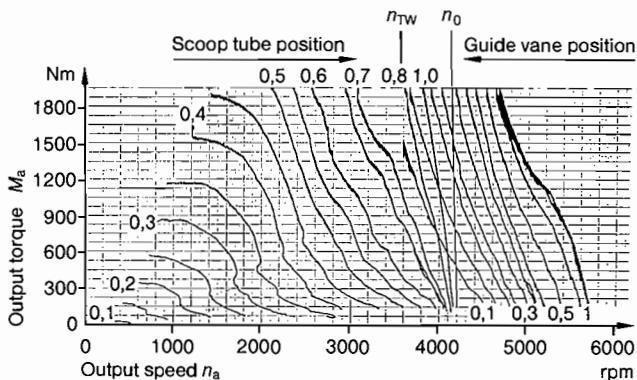

Figure 10. MSVD Multistage Variable Speed Drive, Prototype.



n_{TW} Turbine wheel speed
 n_0 Annulus speed

Figure 11. Prototype: Hydrodynamic Torque/Speed Characteristics.

80 percent of the regulating range could be proved. The hysteresis curve also has been confirmed.

The boiler feed pump characteristic curve is comparable with the one of the retarder results in stable operating points over the whole regulating range. The dynamic behavior required by feed pump drives in case of quick load changes can still be fulfilled, even in case of range changes.

Efficiency Measurement

The efficiency of the MSVD was determined from the power output measured via torque and speed, and the power loss dissipated and measured at the heat exchanger. In this power range, the calorimetric method provides a sufficient measuring accuracy, on condition that the heat dissipation via the surfaces is considered which, of course, has also to be recorded. The efficiencies calculated theoretically could be proved within the measurement with small tolerances.

Smooth Running and Noise

To evaluate smooth running, the housing vibrations were measured according to DIN/ISO 3945 resulting from the VDI Guide Line 2056. Furthermore, shaft vibration measurements or shafting analyses were carried out on all important rotational planes of input coupling and planetary revolving gear based on VDI Guide Line 2159 and API 613. The measurements prove

that the evaluation stage "good" can be achieved in all operating ranges with the compact coaxial gear solution.

DESIGN VARIANTS

By means of the modular design of the multistage variable drive, more design variants can be developed matched to the requirements of the driven machine (Figure 12).

MSVD Standard design

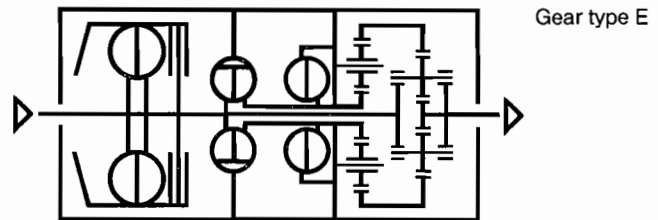

MSVD compact design

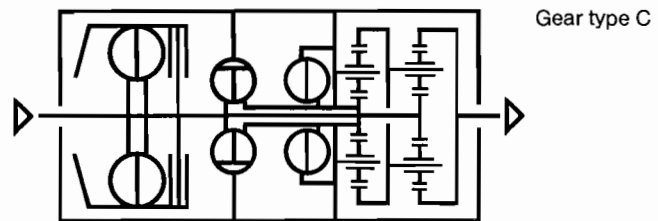

MSVD compact design

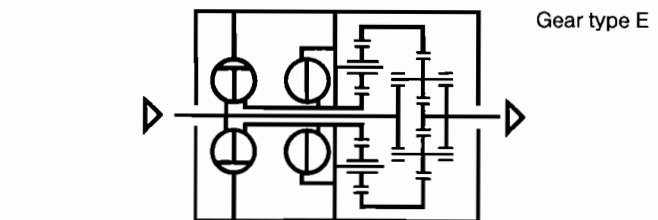

Figure 12. MSVD Design Variants.

The concept of the hydrodynamic converter superposition in coaxial compact design is maintained for all variants.

The adaptations to given or desired input and output speeds and the power to be transmitted are made via the input stage and the type of the planetary gear.

The so-called compact MSVD shown can be used at random except for two restrictions:

- The regulating range is just 50 percent to 100 percent and on motor startup the driven machines runs immediately up to 50 percent of the maximum output speed.
- However, since pumps usually are started against the closed non-return valve and the inertia moment of circulating pumps is relatively low, no problems will result.

POSSIBILITIES AND FIELDS OF APPLICATION

Selection Diagrams

These selection diagrams (Figure 13 and Figure 14) show the output power and speed capacities of some MSVD models with an input speed of 1800 rpm. Output speed ranges up to 20,000

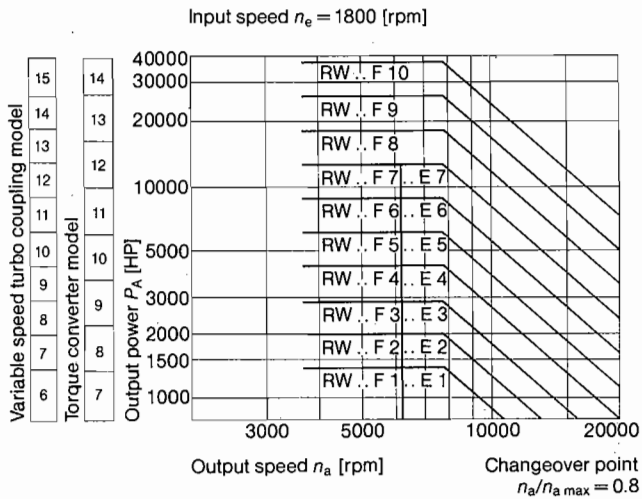

Figure 13. Selection Diagram.

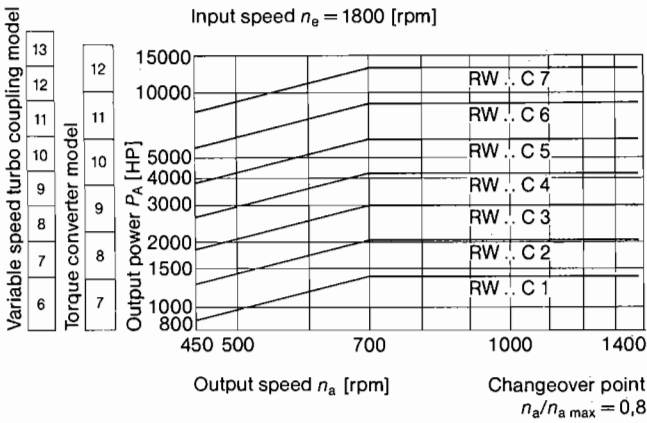

Figure 14. Selection Diagram.

rpm, depending on certain power ranges. The horsepower capacity ranges up to 40,000 hp.

Arrangement Scheme

This scheme (Figure 15) shows two of several basic arrangement possibilities:

- One arrangement shows three × 50 percent boiler feed pumps, two of which are driven by the MSVD and the standby unit by a geared variable speed turbo coupling.
- The other arrangement shows a main shaft drive with one to two shaft gear and a geared variable speed turbo coupling for the standby unit.

Other variants executed are, for example, two × 100 percent arrangement or just one × 100 percent main shaft pump with separate auxiliary pump.

Basic Dimensions

Total space requirements (unit, coolers and controls) for fluid couplings and the MSVD are substantially less when compared with the steam turbine drives or electric variable frequency drives. For example, an 8,500 hp pump drive has the following dimensions: shaft end to shaft end: 142 in, shaft height: 27 in, width between anchor bolts: 71 in (Figure 16).

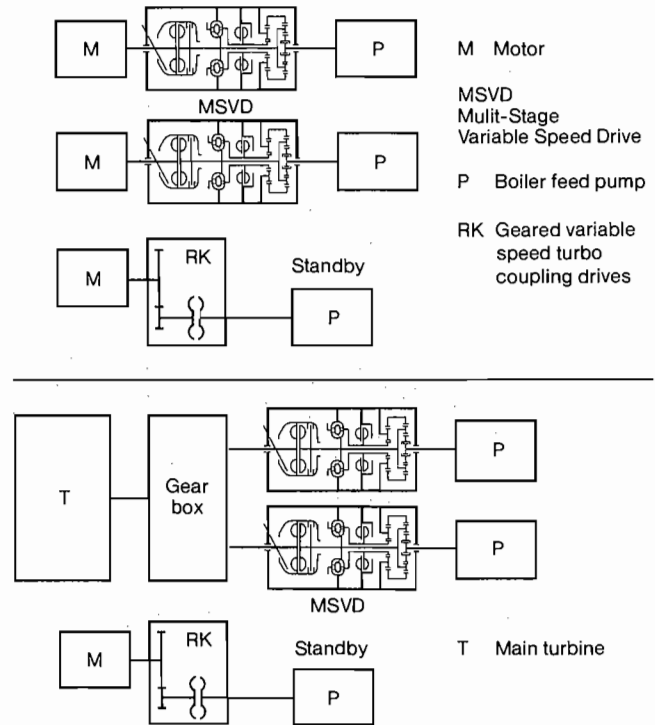
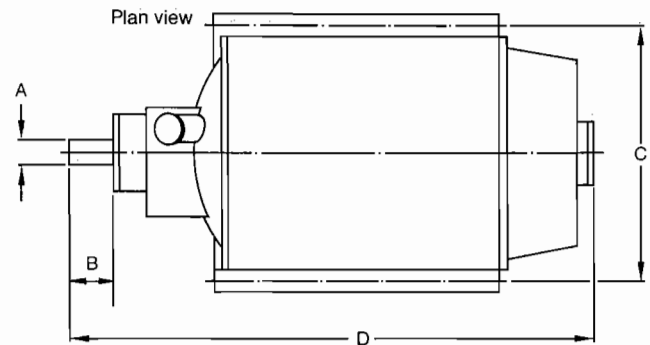

Figure 15. Various Arrangements.



Dimensions in inches

Power	A	B	C	D
2000 HP	4.5	7.0	48.0	105.0
5000 HP	5.0	8.0	56.0	137.0
8500 HP	6.0	10.0	71.0	142.0

Figure 16. Basic Dimensions (for Projecting) MSVD.

COST COMPARISONS

A great number of studies have already been carried out. However, since individual factors are inherent in every application, an example of a boiler feed pump drive in a 410 MW power station unit is provided.

Two pumps at 10,780 hp each and 6130 rpm at test block conditions and a nominal rating of 8260 hp and 5680 rpm were studied. The study was done for four alternatives, using two separate identical drives in each case, as shown in Figures 17 and 18.

- **Alternate 1**
 - two induction motors
 - two geared variable speed fluid couplings
 - two 8260 hp, 5680 rpm boiler feed pumps
- **Alternate 2**
 - two induction motors
 - two MSVD units
 - two boiler feed pumps as in Alternate 1
- **Alternate 3**
 - two variable frequency electrical drives
 - two boiler feed pumps as in Alternate 1
- **Alternate 4**
 - two MSVD units connected to the main turbine shaft
 - three boiler feed pumps as in Alternate 1
 - one induction motor
 - one geared variable speed fluid coupling

6400 Operating hours (avg. load 256 MW) per annum
4000 Operating hours (related to full load 410 MW) per annum

7500 Operating hours (avg. load 273 MW) per annum
5000 Operating hours (related to full load 410 MW) per annum

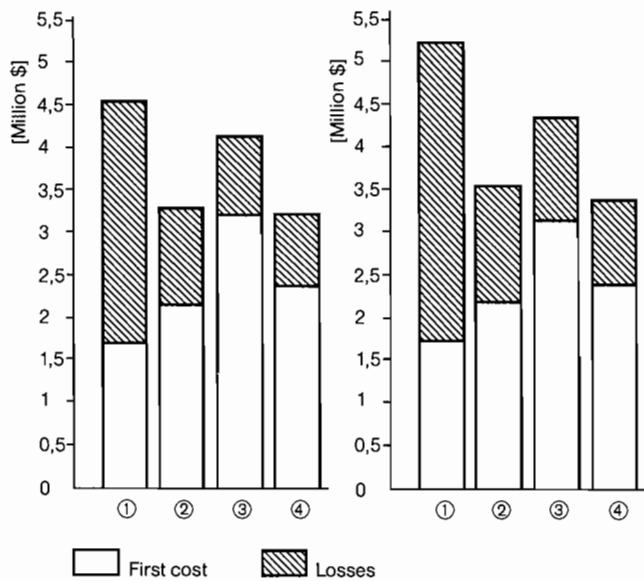

- ① Geared variable speed turbo coupling and squirrel cage motor
- ② MSVD and squirrel cage motor
- ③ current load inverter motor
- ④ MSVD directly driven by the main turbine including standby (startup) units

Figure 17. First Cost and Valuation of Losses.

Typical arrangements for Alternate numbers 2 and 4 are shown in Figure 15, however, for Alternate 2, a standby system of motor, geared variable speed coupling and boiler feed pump was added.

First costs and losses over a 20 year lifespan are shown in Figure 17. First cost includes the motor drive, fluid couplings, boiler feed pumps, switch gear, cabling, transformers, piping and other associated equipment. An inflation rate of five percent per year has been calculated over the time period.

The following table shows a cost comparison between Alternates 1, 2, 3 and 4. The losses over 20 years are calculated for

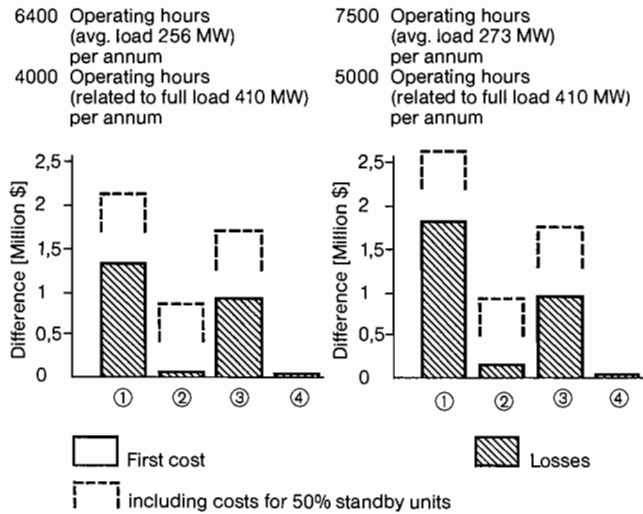

- ① Geared variable speed turbo coupling and squirrel cage motor
- ② MSVD and squirrel cage motor
- ③ current load inverter motor
- ④ MSVD directly driven by the main turbine including standby (startup) units

Figure 18. Difference of Total Costs.

4,000 hours at 410 MW and an average of 256 MW for 6,400 hr. Also, calculations for the same time span for 410 MW at 5,000 hr and an average load of 273 MW for 7,500 hr were made.

Alt.	First Cost	Losses*	Losses*
		Full/Avg. Load 410/256 MW 4000/6400 Hrs.	Full/Avg. Load 410/273 MW 5000/7500 Hrs.
1	\$1,545,454	\$3,363,636	\$3,454,545
2	2,181,818	1,136,363	1,318,182
3	3,136,363	1,045,000	1,181,818
4	2,363,636	1,181,000	1,0945,454

*The losses are calculated over a 20-year period and include bearing losses, gear losses, ventilation losses, hydraulic losses for the hydrodynamic units, and losses of the driver.

The results for the comparison must be looked at for a life extension—plant betterment program and new plant construction differently. In the case of life extension and plant betterment, Alternate 4, which is the most economical overall, is unlikely to be feasible because of restrictive interferences. Therefore, Alternate 2 becomes the most advantageous and economical.

For new construction, Alternate 4 would be the most economical (refer to Figure 18 for differences).

The same methodology is used in Figures 17 and 18. The total cost difference compared to Alternate 4 is shown for the first three alternates, with dotted lines, the additional cost of a standby drive consisting of induction motor, geared variable speed fluid coupling, and boiler feed pump for Alternates 1 to 3. It needs to be mentioned that an alternate using separate steam turbines as drives for the pumps has not been considered.

CONCLUSIONS

The physical and construction details of a new developed multistage variable speed drive have been outlined. A prototype of the coaxially arranged system consisting of proven hydrodynamic/mechanical drive components, has been tested. The

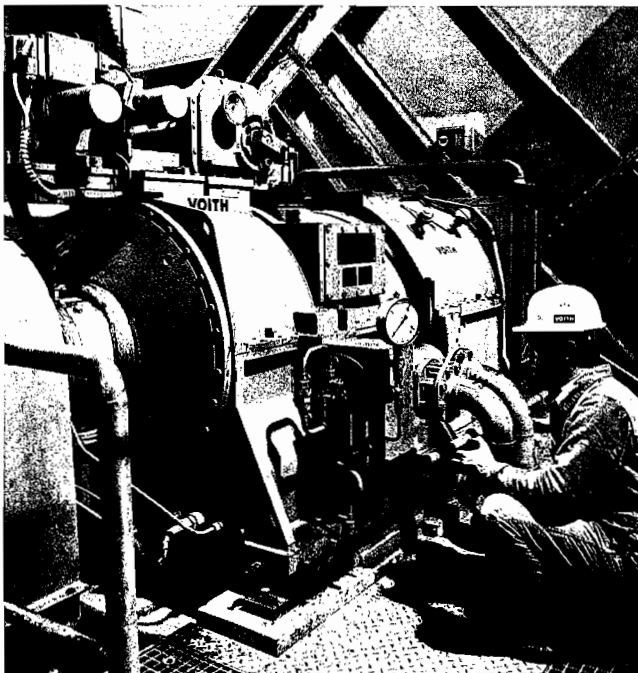

Figure 19. MSVD Fan Drive, 3680 HP, 990 RPM.

measuring results coincided excellently with the previously calculated values. The standards applicable for main drives (operational behavior, dynamics, vibration and noise development) have been fulfilled.

The first drives are built and installed (Figures 19, 20) and performed the first operating hours under load conditions. Thus, the requirements for a start and the resulting operating experience of a new drive series have been satisfied.

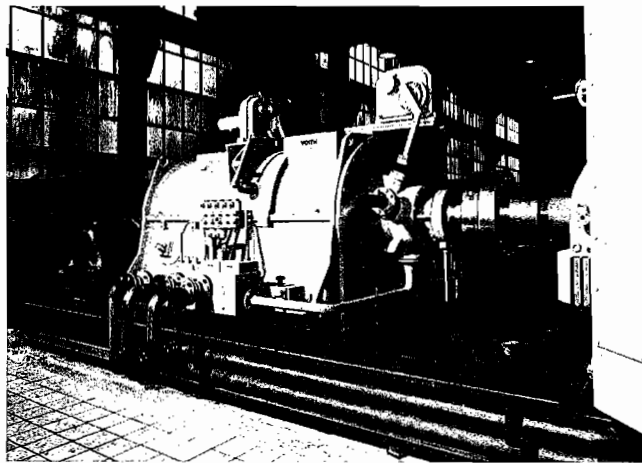

Figure 20. MSVD Compressor Drive, 6800 HP, 3800 RPM.

BIBLIOGRAPHY

- Fechner, G., and Kozlowski, W., "New High Efficiency Hydrodynamic Drive Concept for Utilization in Life Extension and Plant Improvement Programs - Multi-Stage Variable Drive MSVD," ASME/IEEE Power Generation Conference, Portland, Oregon.
- Höller, H. "Multi-Stage Variable Drive - a Hydrodynamic Superimposed Gear with High Efficiency," VDI Reports, (618) (1986).
- Wahl, G., and Suhari, L. "Improvement of Efficiency of Hydrodynamic Variable Speed Coupling - Multi-Stage Variable Drive, a New Development," VGB.