

DEVELOPMENTS IN SEALING TECHNOLOGY WITHIN MULTIPHASE PUMPS

by

John G. Evans

Product Engineering Manager

John Crane EAA Engineering

Manchester, United Kingdom

and

Sido Janssen

Area Sales Director, Special Products

John Crane Benelux

The Hague, The Netherlands



John Evans is the Product Engineering Manager for John Crane EAA Engineering, based in Manchester, United Kingdom. He is responsible for the design and development of new wet seal product ranges and special sealing applications. He also manages the CAD facility throughout the EAA (Europe, Asia Pacific, and Africa) region. He has held various engineering positions within the John Crane organization, including a period spent working in

Japan.

Mr. Evans graduated from Manchester University with a B.Sc.Hons (Mechanical Engineering, 1983).

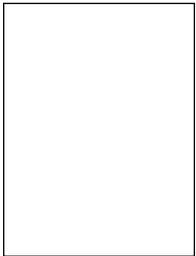

Sido Janssen is Area Sales Director, Special Products, for the John Crane Group, in The Hague, The Netherlands. He works in cooperation with all the major mechanical seal users worldwide and has managed various departments including customer care, buying, production planning, operations, and sales within the Benelux countries. Since 1987, Mr. Janssen has been responsible for the sale of company products on high duty applica-

tions such as hydrofluoric acid, multiphase product, boiler circulation, and high viscosity sealing.

ABSTRACT

The past 20 years have seen the development of multiphase pumping technology to a point today where its use is becoming increasingly viable.

Over this period, equipment suppliers including the major seal makers have adapted and developed products to meet the demanding challenges of this environment. A variety of novel sealing solutions have been applied, very much dependant on the severity of service, which in some cases can require the seal to withstand periods of complete dry running and severe pressure spikes and reversals.

Experience has shown pump and seal makers alike that specified service requirements may differ considerably once in the field, and that equipment must be engineered to cater for this eventuality.

Taking this into consideration and using the latest in materials and surface treatments, mechanical seals have been applied to provide the robustness and reliability required in this market.

INTRODUCTION

The oil and gas industry continues to increase the application of multiphase pumping, as this technology itself develops and becomes more widely accepted as a realistic pumping solution. The economic benefits for developing marginal and deepwater oilfields using multiphase techniques, in certain regions, are now well established. Increased production output, rapid return on investment, and reduced capital investment (as field separator stations are not required) have been clearly shown. While oil prices remain buoyant, the need to develop these fields should see the application of multiphase pumping being driven further forward.

The aggressive nature of multiphase pumping, by virtue of the variability of the pumped fluid—the tendency to have water slugs, high gas volume fractions, and significant solids content—has led to rotating screw (Figure 1) and helicoaxial pumps being the key choices in this market sector.

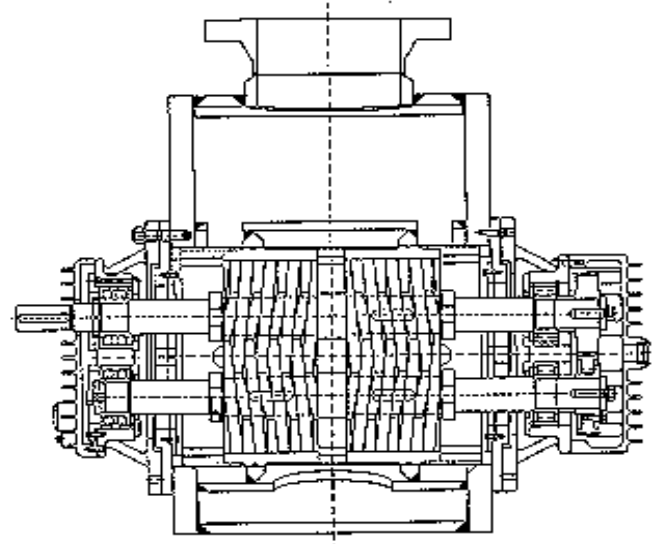

Figure 1. Rotating Multiphase Twin Screw Pump.

It has taken much development work, prototype validation, and infield testing to achieve the current level of acceptability and activity. Despite the progress that has been made over the last 20 years in this area, significant challenges have remained both to the pump design and in the area of sealing.

This paper discusses the challenges presented to multiphase seals and details some novel solutions developed and applied in the field on a variety of multiphase pumping installations. In particular it focuses on some key onshore installations in Venezuela and a

major United Kingdom offshore installation, highlighting some of the ancillary issues that require careful consideration when aiming to maximize seal and pump efficiency on such duties.

Additionally, the paper outlines the results of testing carried out on the latest evolution of a high duty double mechanical seal, when subjected to extreme pressure reversals.

MECHANICAL SEAL REQUIREMENTS

Although each new application clearly imposes specific duty conditions on the mechanical seal, the nature of multiphase pumping presents a number of consistent challenges to the mechanical seal.

- The pumped fluid is usually a mixture of hydrocarbon liquid, water, and gas in any proportion. Additionally, multiphase applications often produce significantly higher quantities of sand.
- The fluid properties can change both over short and long cycles. As positive displacement screw pumps, they may be required to operate for periods at near 100 percent gas, in effect running dry, unless alternative lubrication is provided.
- Fluid viscosity can be high and subject to significant variation with temperature. In some instances, this may be reduced by the injection of a diluent.
- The pressure imposed on the seal can be highly variable and often unpredictable. Sudden pressure spikes and reversals are commonplace.
- Depending on the pump design, the seal is expected to cater for significantly greater axial and angular misalignments than would normally be expected in a "standard" pump configuration. Axial and radial space available for the seal is often limited.
- Low, variable, and high speed operation, each presenting differing challenges for the seal. Screw pumps often operate in the range 300 to 3600 rpm, and the helicoaxial pumps, in the range 1800 to 6000 rpm.

Both double and single sealing arrangements are currently used in multiphase pumps. Within both designs, specific features and techniques have been introduced to cater for the aggressive service. The ability to accept high degrees of misalignment and handle highly viscous products is common to both arrangements.

Single seals often also need to cater for periods of dry running at startup while gas fractions are high. Under these conditions, the lack of liquid lubrication to the seal faces gives rise to high degrees of contact friction, resulting in a rapid rise in heat loading, temperature, and ultimately to seal failure. This is often due to fracture of one or both faces. In some cases, this fracture occurs on reestablishment of the liquid regime, giving rise to a sudden thermal shock. It is this specific "dry running" condition that tends to limit the application of single seals to the less severe multiphase applications—for instance, on smaller pumps where seal loading is lessened and on applications where the *gas volume fraction* (GVF) of the fluid does not impose full dry running requirements on the seal.

In those circumstances where a single seal has been specified (usually due to limited space availability) and on a high GVF application, it is normal for a flooded circulation from suction, or a Plan 11 fluid supply from discharge, to be provided. Alternatively, the addition of a diluent injection into the seal area can be provided to prevent the seal seeing a truly dry environment. This however is a costly addition to the overall pumping arrangement and is usually only made available to the seal when the pump itself requires diluent to reduce the viscosity of the pumped fluid.

It is for this reason that seal makers have introduced enhancements to their designs to overcome this weakness. One such arrangement is shown in Figure 2 and discussed in the following section.

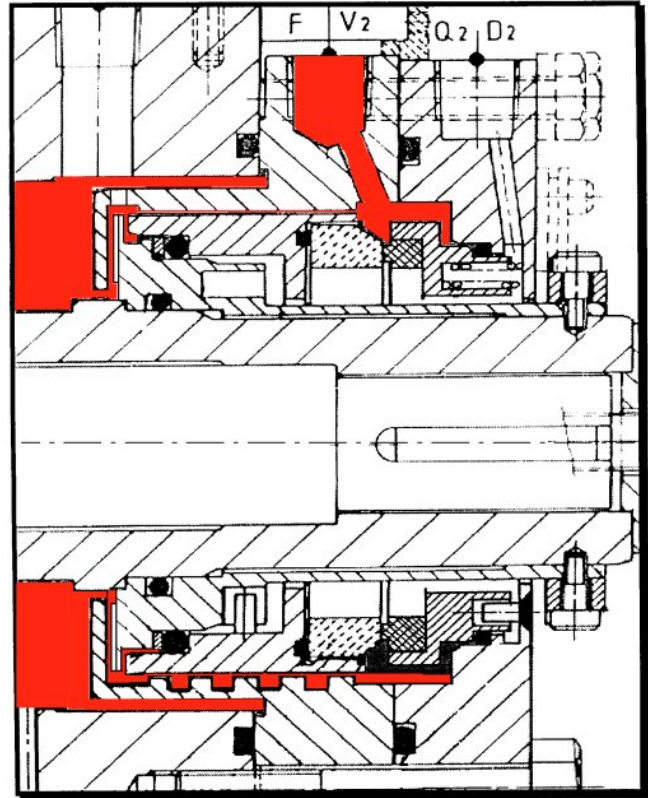

Figure 2. Single Seal for Multiphase Pump (A).

Clearly this problem of dry running can be eliminated with the introduction of a double seal and pressurized sealing system. In the ideal world this should provide a complete solution. Due care must be taken in designing the seal and selecting barrier oil pressures as, with the fluctuating nature of pressure, the double seal may be exposed to severe pressure reversals.

ALTERNATIVE SEALING SOLUTIONS

Single Seals

Initially, the first multiphase pumps were simple derivatives of liquid screw pumps and, as such, the space available for the seal tended to be limited, forcing the use of simple single seals. Their use was targeted at low GVFs, typically less than 30 percent. As the capability of such pumps improved, the simplicity of the single seal arrangement became popular in some areas, as they allow a shorter distance between bearings and no ancillary equipment, although the bearing oil flush from the atmospheric side can be used to lubricate the seals.

As mentioned previously, however, the remaining weakness remained in their ability to tolerate sustained periods of dry running. In order to operate successfully up to 70 percent GVF, special features have been developed within the sealing arrangement, some of which are shown in Figure 2. The key features include:

- Stationary springs to minimize fatigue under high misalignment.
- Substantial clearances to cater for misalignment.
- Top-polished (surface textured) SiC/SiC or SiC/hard carbon face materials.
- Eccentric screwed stator and fluid retention reservoir for enhanced dry running.
- Self cleaning sand expeller.

While being unique, the principle of the seal is simple. Under normal liquid operation, the seal is supplied with a Plan 11 flush

from pump discharge, through the seal cavity and into the stuffing box. The fluid is required to lubricate the faces and remove any heat generated.

In the event of a gas slug, the Plan 11 flush may not be sufficient and the seal may, in effect, run dry. To prevent this, the solution is to design the seal cartridge in such a way that a small quantity of oil is maintained around the seal faces. This provides adequate short term lubrication, and limits the temperature rise and eventual thermal gradient imposed on the seal once liquid conditions are reestablished. The addition of the fluid reservoir formed by the weir in the seal housing and the inclusion of the eccentric screwed stator prevents any liquid already present around the seal from escaping (Figure 3). The screwed stator also acts to pump the remaining fluid over the faces and provides internal circulation and cooling during the period of gas pumpage. In so doing, the seal remains lubricated and ready to seal the pumped fluid, once liquid flow is reestablished. The rotating assembly uses a large section O-ring for secondary sealing, which permits self alignment and is able to absorb the effect of shaft deflections.

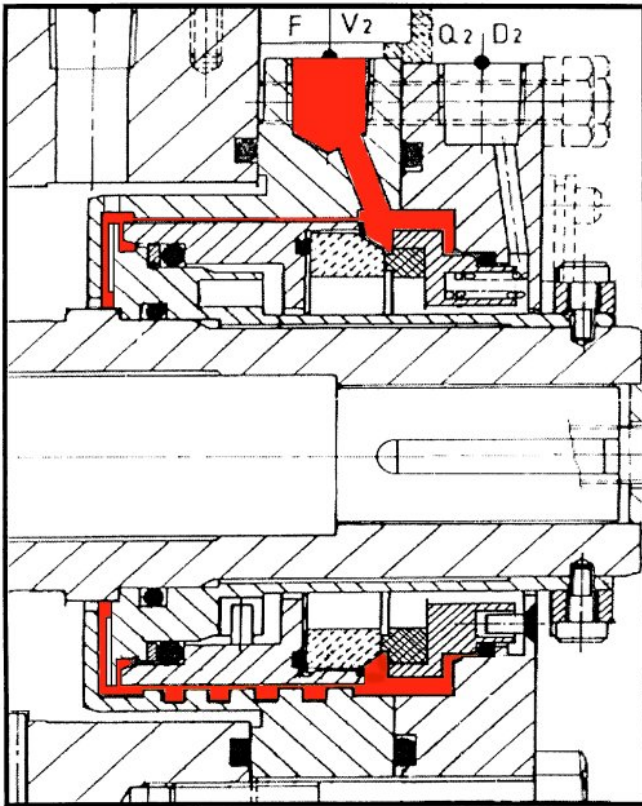

Figure 3. Single Seal for Multiphase Pump (B).

Testing in Holland

During the development of this design, several tests were carried out to demonstrate this principle.

In one of the tests, the seal and stuffing box were first statically tested to 60 bar (870 psi). The seal was then run for a period at 35 bar (507 psi) and 3000 rpm to establish equilibrium conditions. With the pump still running, the stuffing box was then drained to simulate dry running and was pressurized with air at 7.5 bar (108 psi). The seal was then run for a further 30 minutes, monitoring seal face temperatures. At the end of the test, the components were inspected and found to be as-new.

These tests were repeated, including running with sand and sludge present. Again, the seal performed admirably with no indications of dry running.

This type of solution has given the pump maker the option of using more compact simple solutions to address a significant portion of the multiphase market—that where pressures are lower when the GVF is less than 70 percent.

Double Seals

As far back as the early 80s, when multiphase technology began to develop in Europe, the double seal was leading the way on the most arduous of services, irrespective of pump manufacturer or end user.

Seal manufacturers developed compact double cartridge seals to cater for the high static and reverse pressures stipulated. One such development had the following operating conditions:

- Pumped Fluid: mixture of crude oil, gas, water, NaCl
Fluid temperature: 75/130/10°C (167/266/50°F) (norm/max/min)
Viscosity: 0.4/20 cP
- Forward dynamic:
Pressure: 10/150 bar (145/2175 psi) (norm/max)
- Static reverse:
Pressure: 99/150 bar (1435/2175 psi) (norm/max)
Shaft speed: 3000/3600/1200 rpm (norm/max/min)
Shaft diameter: 140 mm (5.51 in)
Barrier pressure: 88 bar (1276 psi)

Figure 4 shows a typical seal design of that time. The simple stationary sprung construction permitted operation over a wide range of speeds and sizes. The stationary face was a three-part construction, using a steel band and carrier to sandwich a carbon seal ring to form the face assembly. This construction provided the seal with a high pressure capability in both forward and reverse directions (for example, upon loss of barrier fluid pressure), over a wide temperature range. This “squeeze design” construction was developed to be a popular solution on other applications requiring a robust pressure/temperature characteristic, including metal bellows seals, and went on to be used by several other seal vendors.

Although initial trials were conducted with a silicon carbide versus carbon face pairing, it eventually became evident that, for two reasons, a hard/hard pairing would be preferable.

On one occasion, a trial seal in the North Sea was inspected following several months running. The seal had begun to show increased barrier oil leakage into the pump and, upon inspection, it was discovered that virtually all the carbon seal “nose” had been eroded by sand—on an application where sand was not supposed to be present. The carbon was replaced by tungsten carbide, which eliminated the erosion problem.

On another occasion, a trial pump in Tunisia failed to achieve a critical 1000 hour endurance test due to seal face blistering. Although similar in configuration to the original seal, the replacement seal used a silicon carbide/graphite composite material in place of the carbon and went on to achieve the 1000 hour result.

Both these experiences were turning points in the evolution of multiphase sealing. Besides the obvious technical lessons learned—guard against erosion with two hard faces and use composite materials to eliminate blistering—they demonstrated that, by its nature, multiphase pumping conditions are difficult to predict and that the specification cannot be wholly relied upon. In the intervening years, applications introduced further challenges and solutions culminating in the seal design shown in Figure 5. At first sight it appears to be a relatively standard double seal. However, it is the inclusion of some key features that makes this seal so suitable for multiphase service. These features include:

- Through spring design that permits ± 3 mm ($\pm .12$ in) axial movement without any affect on face loading due to the springs.
- Inboard double balance feature to guard against seat ejection under upset conditions and provide run on capability.

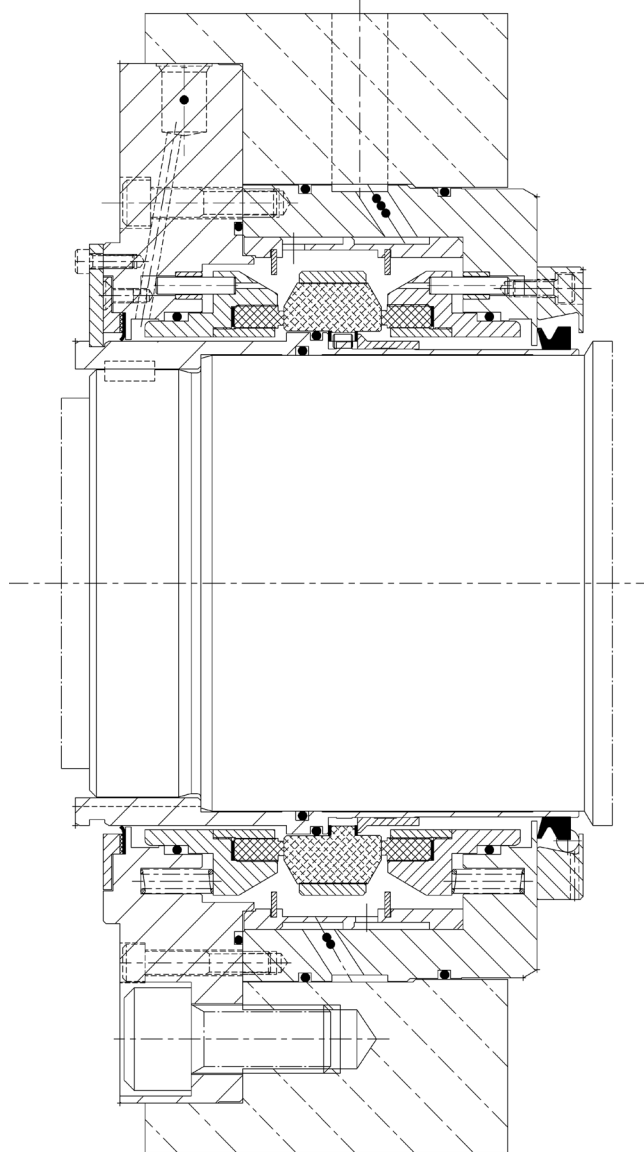

Figure 4. 140 mm (5.52 in) Double Seal from 1980s for Multiphase Pump.

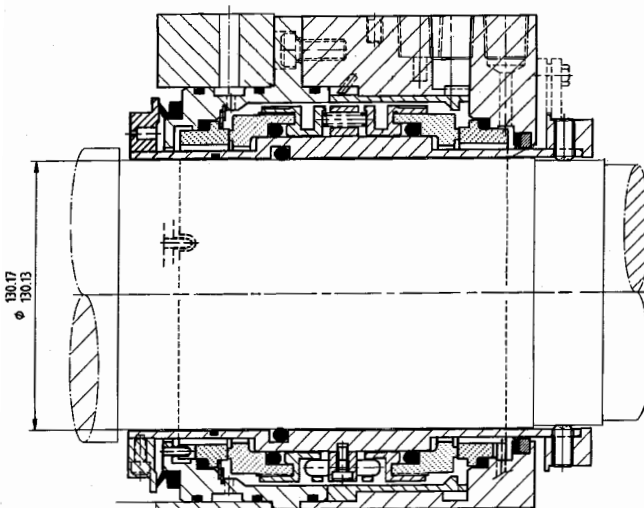

Figure 5. 135 mm (5.32 in) Double Seal for Multiphase Pump.

- Hardened Monel® nickel alloy drive pins to eliminate hangup associated with fretted drive devices.
- Two hard face pairing for both inboard and outboard incorporating unique top-polishing treatment. A method of enhancing SiC versus SiC performance, by encouraging forced face lubrication, removal of heat, and reducing friction. Figure 6 is a graph showing these differences in relation to the amount of “top-polishing” applied.

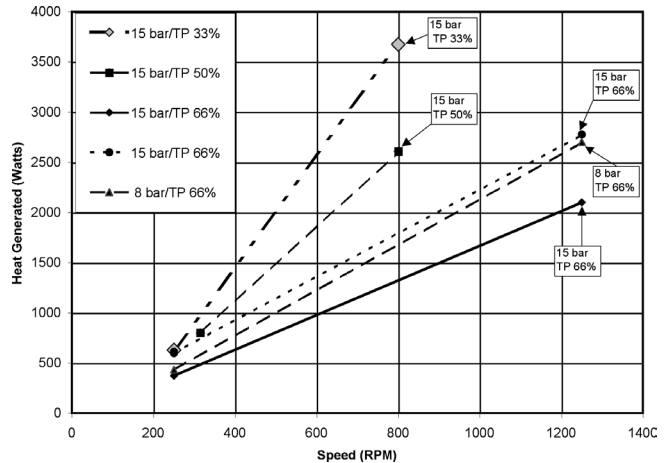

Figure 6. Graph Showing Benefit Offered by Top-Polishing.

- Generous clearances to cater for excessive misalignments.
- Various inboard seal protectors offered to guard against product clogging around the inboard seal.
- Optional pumping ring subject to speed and circulation requirements.

However, one recent experience in Venezuela has shown, once again, how *multiphase pumping can challenge the most fully engineered seal*. In this project, 84 double seals were supplied, being fitted on an initial quantity of 21 twin screw multiphase pumps. The seals were to be supported by a single API Plan 54 open loop pumped seal system for each pump, i.e., four seals. The typical operating conditions are:

- Suction pressure: 6 barg (87 psig)
- Discharge pressure: 49 barg (710 psig)
- Product: Diluted crude oil, gas, water and 5 percent sand
- Product temperature: 30 to 50°C (normally 38°C) (86 to 122°F (normally 100.4°F))
- Speed: 250 to 1200 rpm

The initial service specified for the seals was a box pressure of 6 barg (87 psig) and on that basis, a barrier pressure of 15 barg (217 psig) for the API Plan 54 system was specified.

Despite several suggestions on the part of the seal maker that it would be more usual to use the discharge pressure as the basis for the seal system rating, the barrier pressure remained specified at 15 bar (217 psi). Later on, it was decided that there might be a possibility of the seals seeing as much as 21 bar (304 psi) due to spiking. For that reason, the barrier pressure setting was revised to 27 bar (391 psi)—in effect giving a 21 bar (304 psi) differential against the normal box pressure. At this stage, concern was raised by the end user that, in virtually doubling the barrier pressure, the seal system cooler would not be capable of removing the additional heat generated by the seals.

An API 682 100 hour type test was carried out under the 15 bar and 27 bar (217 psi and 391 psi) conditions with constant circulation flow rate and the heat generated and leakage levels

monitored. The results are shown in Table 1 and, as can be seen, the effect of almost doubling the pressure had no detrimental effect on heat generated or leakage. As predicted, the design of the seal components and the top-polishing (a form of seal face profiling) give extremely low effective coefficients of friction.

Table 1. Result for 135 mm (5.32 in) Double Seal—Heat Generated and Leakage.

Pressure (bar g)	Heat generated (kW)	Leakage (ml/hr)
15	2.09	2.2
27	2.15	2.2

It had always been assumed that at startup there may be some short term pressure reversal up to 3 bar (43 psi) for a few minutes and, as part of the supply, the seals underwent this test. Following a 15 minute test under this condition, no product had leaked into the barrier, and on inspection the seal faces appeared as-new.

Initial Experiences at Site

The pumps were initially commissioned in October 2000, but it was not until early in 2001 that they were run to maximum capacity, under full service conditions. After several early seal failures, it became evident that the seals were being subjected to an operating condition not called for in the specification. On one occasion, the inboard silicon carbide seat fractured, and there was evidence of heavy contact against antirotation pins. The suspicion was that the seal was being subjected to substantial reverse pressures during the starting phase of the pumps. It was decided to carry out a short test program in Manchester to simulate theoretical site conditions, and then impose increasingly more difficult conditions of pressure. During this period, it was also decided to introduce some small improvements to the drive mechanism, as a guard against further carbide fracture.

Testing in Manchester

In order to test the seal as closely to pump operating conditions as possible, an arrangement was devised whereby the seal could be tested with a pressurized fluid supplied from an API Plan 54 seal system, and on the product side be exposed to a highly viscous oil. This fluid was supplied by a local refinery to match a sample from site. The product itself was not circulated, as on the pump.

The test rig permits variable speed operation up to 6000 rpm and testing was carried out at speeds of 300, 600, 930, and 1250 rpm. An additional final test was also carried out at 1800 rpm.

Figure 7 shows a test rig schematic—by using a “dummy seal” on the opposite end of the rig, hydraulic loads can be balanced. A summary of the test carried out is shown in Table 2.

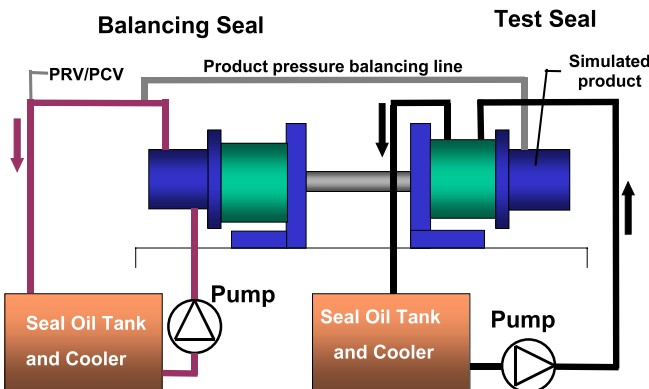

Figure 7. Schematic Circuit for Multiphase Seal Tests.

Table 2. Test Summary for 135 mm (5.32 in) Double Seal.

Test #	Barrier Pressure (bar g)	Product Pressure (bar g)	Speed (RPM)	Duration (Hours)
1	27	6	300	0.5
	27	6	600	0.5
	27	6	930	3.0
	27	6	1250	3.5
2	27	24	300	0.3
	27	24	600	0.3
	27	24	930	0.5
3	27	6	300 - 600	2.0
	27	30	300 - 930	0.5
	27	30 - 6	930	0.5
4	27 - 24	30	300	0.6
	-	with spikes from 24 up to 45 over 5 secs	-	-
	-	6 - 24	300 - 1250	0.6
	27	-	-	-
5	27 - 24	30	300	0.3
6	27 - 24	30 - 20	300 - 1250	0.9
		with spikes from 24 up to 45 over 5 secs		
7	24	36	300 - 600	0.1
8	35 - 55	30 - 6	300 - 1800	1.2

Testing was split into two phases—phase one concerned the standard seal. Tests 1 and 2 represented normal equilibrium and startup conditions. On startup the pump pressure can remain high, while the pump speed increases.

In Test 3, a condition beyond the specification was introduced, namely a 3 bar (43 psi) reverse pressure startup, lasting for 30 minutes, mostly at 600 rpm—substantially more arduous than the original “API 682” tests.

Test 4 went one step further. During the testing in Manchester, investigations revealed that, in reality, the seal might have been exposed to pressures up to 45 bar (652 psi) or higher (substantially more than the original 6 bar (87 psi)). The seal was therefore subjected to numerous static pressure spikes, resulting in a reverse pressure of 21 bar (304 psi). Additionally, the seal was now started under a reverse pressure of 6 bar (87 psi), as there was some doubt that the barrier pressure at site, around the seal, was as high as the supply pressure.

Then in Test 5, the product was allowed to cool to 2°C (35.6°F) overnight (this was Manchester in February) to maximize viscosity on startup. At site, although normal temperatures are 35°C (95°F), temperatures can drop as low as 16°C (60.8°F) overnight. Figure 8 shows the consistency of the product following this test—in effect, any imprint made in the oil remained—there was sensibly no flow.



Figure 8. Photograph of Product Used on Test for 135 mm (5.32 in) Double Seal.

Having thrown all these unusual conditions at the seal, the components were inspected. The seal faces and seats were immaculate, as-new, with no signs of grooving or marking, which might be expected when running under reverse pressure. The only component that showed signs of wear was a polytetrafluoroethylene (PTFE) sleeve that fits over the single seat antirotation pin. A characteristic of this material is that it flows under pressure and the sleeve became split at the point of local loading, resulting in contact between the pin and seat itself—but no damage was caused to either component.

Testing had therefore shown that the seal was not only capable of the original duty, but in fact far more and had shown no signs of the symptoms at site with the exception of the split PTFE bush.

In any event, the seal was modified to incorporate three antirotation pins in the seat, which were fitted with a more robust Viton® sleeve to cushion any impact loads on startup.

The sequence of testing was repeated in Test 6. For Test 7, an even higher reverse pressure at startup of 12 bar (174 psi) was introduced.

It had become clear through the testing that actual site conditions were almost impossible to predict. It was highly likely that the seal would see pressures up to 50 bar (725 psi) and that running dynamically under reverse pressure at this level would not be a reliable way to operate the pumps. For this reason, on Test 8 it was decided to evaluate seal performance when operating with a barrier fluid pressure up to 55 bar (797 psi). This was carried out over a speed range of 300 to 1800 rpm. The seal performed without fault throughout the test, and at 55 bar (797 psi), *nearly four times the originally specified value*, there was no significant change in the power absorbed by the seal. Figure 9 shows the heat generated by the seal at varying speeds and pressures, which corresponds to the low coefficient of friction achieved by the “top-polished” seal faces.

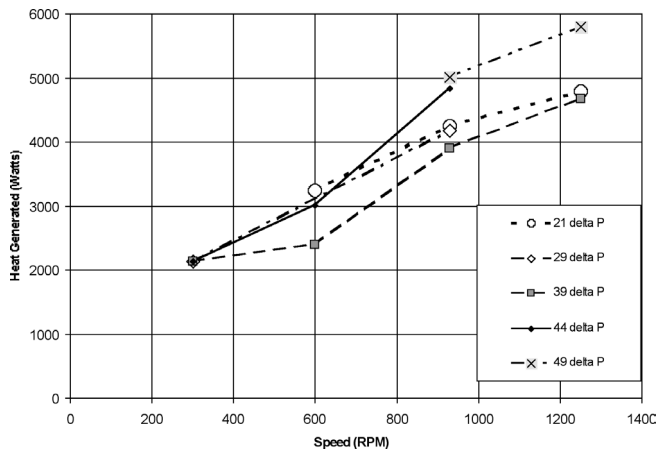

Figure 9. Graph Showing Heat Generated for 135 mm (5.32 in) Double Seal.

Lessons Learned

Quite clearly, as has been stated before, multiphase pumping technology is, relatively speaking, still in its infancy and often the geographical regions where it is applicable do not necessarily allow easy access to information. Fortunately in this instance, a substantial degree of redundancy had been included in the seal design as a result of previous development work, but even having questioned the logic of pressure settings, it was still possible to end up in a failure situation.

In fact, there were other factors affecting the initial reliability. For instance, the seal system, once it was set to operate at the 27 bar (391 psi) condition, was operating at the extreme of its envelope and this led to several gear pump drive failures. Although a “safety package,” to prevent sudden loss of pressure under this condition or

in power failure, had been included, its reliability was questionable. Likewise, the construction of the system was not conducive to maintenance, brought about by a drive to minimize costs.

Probably the most significant factors in affecting the initial reliability were associated with startup and operating procedures.

- *First*—The decision at site not to go ahead with a planned injection of diluent at startup. The benefit of which would have been twofold—the seal area would have been exposed to a clean, low viscosity product reducing any risk of damage or hangup and pressures around the seal would have potentially been more predictable.

- *Second*—The initial starting procedure called for extended running (approximately 40 minutes) at 300 rpm followed by a phased increase in speed, resulting in an increased duration of reverse pressure running. Subsequently, this procedure was revised to improve conditions.

- *Third*—Pressure spikes necessitated an increase in system pressure, in effect almost double the original specification.

- *Fourth*—The purging procedure for the pumps before startup became important, as pumped product from the wells entering the multiphase pump can induce shock to the seals. A bypass circuit has been added to aid purging and overcome irregularities during filling the pump cavity.

At the time of writing (August 2001), the modified seals and procedures have been in place for four months without further problems.

Experience in the North Sea with Double Seals

Many of the early field trials with multiphase pumping in the 80s were carried out in the North Sea. In 1998, high duty seals were supplied on the highest pressure helicoaxial multiphase pump in service. Four single seals are fitted to each of the vertical pumps. A pair of seals at each end of the pump is used to form a double seal. Between each seal is located a steady bushing. The service conditions are:

- Suction pressure: 20 to 160 bar (290 to 2320 psi)
- Discharge pressure: 135 bar (1958 psi)
- Barrier supply pressure: 145 bar (2103 psi)
- Product: Crude oil, gas, water, and sand
- Pumped temperature: 80°C (176°F)
- Shaft size: 130 mm (5.12 in) stepped to 116 mm (4.57 in)
- Speed: 1800 to 6000 rpm

One novel feature within the seals was the inclusion of pumping scrolls. The barrier fluid supplied to the seal was also used as the lubricant for the bushing and it was a requirement of the sealing arrangement that a pressure drop of around 70 bar (1015 psi) be achieved across the bushing. This required a flow of 150 L/min (33 gal/min) to pass over the seals and through the bushing. It was felt that this flow rate would be excessive if injected directly over the seal, and therefore the scrolls were used to recirculate a portion, around 30 L/min (6.6 gal/min), of the total flow, thereby eliminating any erosion problems (Figure 10).

The seal and bushing arrangement is shown in Figure 11. The initial supply pressure of the fluid over the inboard seal is 140 bar (2030 psi), which results in a differential pressure across this seal of 20 bar (290 psi) (at startup) and 90 bar (1305 psi) (normal). The 140 bar (2030 psi) pressure is then broken down to 70 bar (1015 psi) through the bush and therefore the outboard seals see a differential of 70 bar (1015 psi). The pumps operate at 1800 rpm to 6000 rpm, although at the time of writing, most operation was in the 3500 to 5500 rpm range.

Experiences on Test

The seals underwent a detailed test program in Manchester, prior to dispatch, over the complete speed and pressure range. During

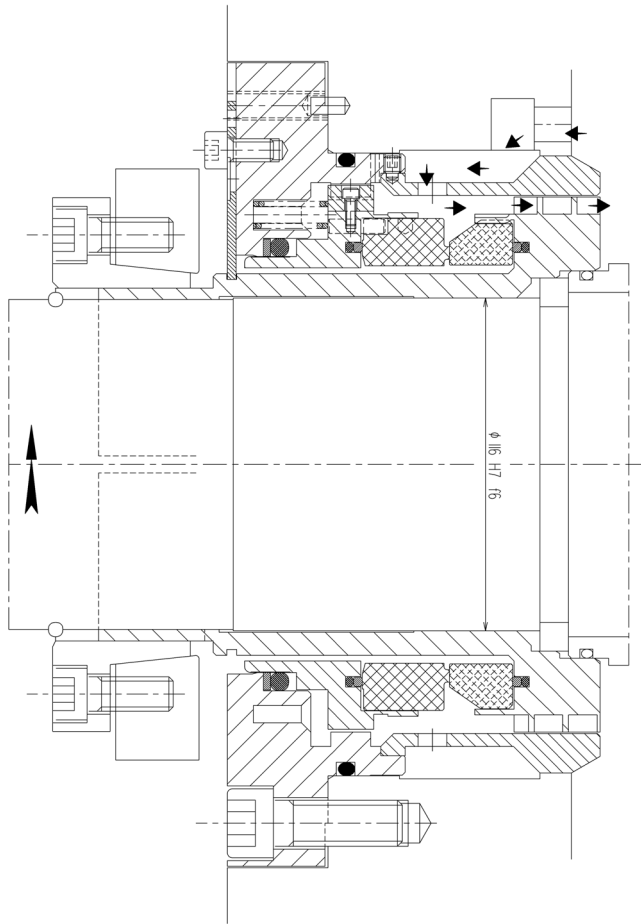

Figure 10. High Duty Single Seal for Helicoaxial Multiphase Pump.

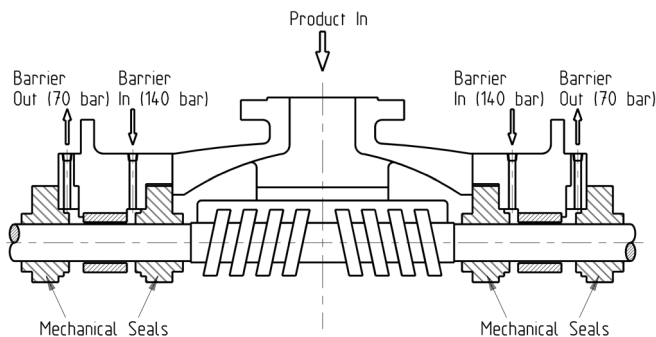

Figure 11. Helicoaxial Pump Showing Seal and Bushing Arrangement.

this testing, it was realized that the oil intended for use as the barrier contained metallic additives. Additives are classified as materials that impart new properties to enhance existing properties of the lubricant. Typically these include oxidation or bearing corrosion inhibitors and antiwear additives, for which zinc dithiophosphates are widely used.

These additives not only inhibit oxidation but also form a protective film on surfaces, intended to make them impervious to acid attack. Within a mechanical seal, such oils can give rise to serious problems beyond certain levels of speed and pressure as the additives adhere to the seal faces. The formation of deposits on seals faces brought on by these additives is well documented within the seal industry. In this case, it resulted in rapidly increasing leakage rates when operating for more than a few hours

above 3500 rpm, and it is for this reason that oils free from metallic additives are always preferred. The oil was changed to the preferred standard—a heat transfer oil ISO VG 8—and the problem disappeared.

Problems Offshore

Initial reliability of the seals was not good, with leakage increasing after only four to six weeks operation. Several operational problems were identified and rectified over a period of time.

- During the early months, there had been several instances where the barrier pressure had been allowed to spike to around 180 bar (2610 psi). These seals used carbon as the face material and, at these pressures, permanent deformation can be locked into the seal rings, resulting in high degrees of local contact and face chipping. A change to the valve operation sequence was introduced to eliminate this problem.

- Seal face damage and the formation of product-based deposits seemed more prevalent on the “topside” product seal. This seal tends to be in contact with the more gaseous fractions in the pump. It was theorized that the combination of elements in the product and temperature from the seal faces was reacting at the seal, leading to the formation of deposits. A program of work was undertaken to reduce temperatures. This involved running the seals to validate the face temperature, followed by a series of tests to simulate site conditions, while the composite seal ring temperature was being monitored using thermocouples. Twenty 10-hour cycles were conducted under the following conditions:

- Static: 135 bar (1958 psi) for 10 min
- Dynamic:
 - 1800 rpm; 10 bar (145 psi) for 10 min
 - 3500 rpm; 33 and 55 bar (478 and 797 psi) for 2 hr
 - 5000 rpm; 75 bar (1087 psi) for 6 hr
 - 6000 rpm; 90 bar (1305 psi) for 30 min

Figure 12 is a graph showing typical performance during this test. In particular, the face temperature remains more stable with the new material and seal leakage is much more controllable. A comparable carbon test gave temperatures in excess of 180°C (356°F).

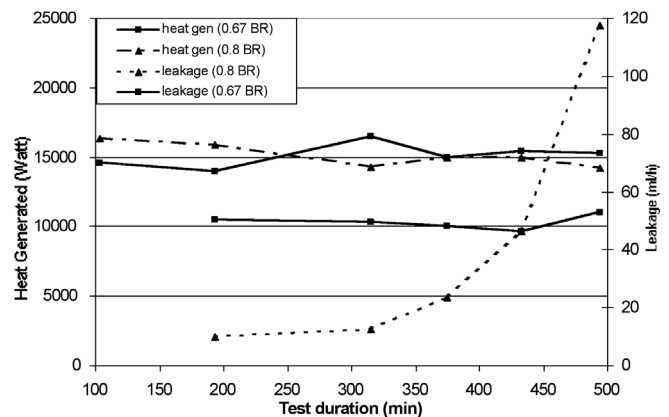

Figure 12. Graph Showing Leakage and Heat Generated with Different Conditions.

With successive seal failures came a significant presence of water in the barrier oil tank. This water within the oil was now causing problems of vaporization on the outboard seal. Additionally, the oil system gear pumps were going through a patch of low reliability, thought again to be due to the water content. Oil pump failure induces an “emergency shutdown” (ESD) of the pump. Water ingress was occurring either via the inboard seal faces or from an external source, e.g., rain or waves,

etc. Analysis of the water and sludge suggested that it was not sea water, and several improvements were made to the venting and sealing of the oil tank, by applying a low pressure positive air purge blanket. It was eventually concluded that condensation was the major culprit, although the quantities involved might suggest there may have been an additional source.

- Inspection of the seal components following failure then began to show a common theme, with at least one of the inboard carbon faces being cracked through—typical of a tensile stress. Attention turned to the possibility of an unknown reverse pressure, sufficient to break, then carbon being present. Tests were carried out on carbon rings to determine their realistic strength and four rings failed repeatedly at 50 bar (725 psi). It was eventually realized that such a pressure could exist. Increasing the barrier pressure was not an option at this stage and, therefore, it was decided to increase the tolerance of the seal components to withstand this pressure. The earlier decision to move to the graphitized SiC for thermal reasons actually presented the pressure solution, as that material would give an automatic doubling of strength over the carbon.

- At the time of writing, the graphitized material is about to go into service. The reliability of the carbon seals has increased inordinately since making changes to the operation. One set of seals was recently removed, which had not failed and had operated for almost six months.

CONCLUSIONS

- Significant progress has been made over the past two decades in bringing multiphase pumping technology to its current level of economic viability.
- Improvement in sealing technology has been one of the major challenges in achieving acceptable pump reliability.
- Novel solutions have been developed to optimize the use of both single and double seals.
- The predictability of well and site conditions can still be unreliable.
- Design ratings of seal and support systems must consider “worst case” scenarios for maximum reliability.
- Multiphase pumping is set to grow considerably in coming years, and the sealing industry has demonstrated its ability to meet the challenges and provide reliable solutions.

ACKNOWLEDGEMENT

Contribution and help in compilation from D. E. Cadden, Chief Design and Development Engineer, John Crane Engineering EAA.

Testing and evaluation services from P. Phelan, John Crane EAA, Product Development Centre Manager, Manchester.