



**FACTORS AFFECTING OIL RING AND SLINGER LUBRICANT DELIVERY & STABILITY**

**Simon Bradshaw**

Director of API Product Development & Technology  
ITT Goulds Pumps  
Seneca Falls, NY, USA

**Jeremy Hawa**

R&D Development Engineer  
ITT Goulds Pumps  
Seneca Falls, NY, USA

**John Salerno**

Owner  
JCS Design  
Waterloo, NY, USA



Simon Bradshaw is the Director of API Product Development & Technology for ITT Goulds Pumps, in Seneca Falls NY. His responsibilities include the design and development of new products and processes. Prior to joining ITT Goulds, he worked for both Sulzer Pumps and

Weir Pumps, where he held various positions of engineering and contractual responsibility. Additionally he has supported the Hydraulic Institute in the development of pump standards and best practice guides.

Mr. Bradshaw has a BEng (Hons) degree (Mechanical Engineering) from Heriot Watt University. He is a registered Chartered Engineer in the UK and a member of the Institute of Engineering Designers.



Jeremy Hawa is a Product Development Engineer with ITT Goulds Pumps, in Seneca Falls NY. His responsibilities include design and development of new pump products and processes for the oil and gas markets. This specifically includes new bearing housing design for all API 610 compliant product lines.

Mr. Hawa has a B.S in Mechanical Engineering from SUNY at Buffalo.



John Salerno is the owner of JCS design in Waterloo NY. He provides design and engineering services on a contract basis.

Mr. Salerno worked for Goulds Pumps in Seneca Falls NY for 36 years. Prior to his retirement he held the position of supervisor, responsible for the research and development designers. Additionally he has served as the engineering system administrator.

He attended Rochester Institute of Technology (RIT) in their Mechanical Technology Program.

**ABSTRACT**

The choice of which lubrication strategy to apply for pump bearings has implications for both the short term characteristics exhibited by the bearings and their long term reliability. When lubricating rolling element bearings, four basic strategies have historically been employed:

- Grease lubrication
- Oil bath lubrication
- Oil lubrication via slinger disc or oil ring
- Oil mist lubrication

For high speed (3000 RPM and higher), slinger discs or oil rings are commonly used due to the short re-greasing interval exhibited with grease lubrication and the high heat generation due to churning seen with oil bath lubrication.

This paper seeks to reprise the work of Lemmon & Booser, Heshmat & Pinkus, Gardner and Ettles et al in defining the equations of performance related to oil slinger discs and oil rings. It will then address some of the operational and reliability concerns of each of these oiling methods using a purpose built test rig that is representative of the current state of the art in bearing housing design for pumps.

Specifically it will look at how the following parameters affect oil delivery and stability:

- Rotational speed
- Bearing housing inclination
- Oil ring material
- Slinger geometry
- Slinger and oil ring submergence depth

## BACKGROUND

The lubrication methods for horizontal pump rolling element bearings are widely known and many preferences exist among the users and manufacturers of pumping equipment.

For smaller bearing arrangements and slower speeds oil bath lubrication arrangements are commonly employed. In these arrangements the normal oil level is set at around  $1/3^{\text{rd}}$  to  $1/2$  of the diameter of the rolling element ball (or roller) as shown on Figure 1. These arrangements have the advantage of simplicity of design and manufacture.

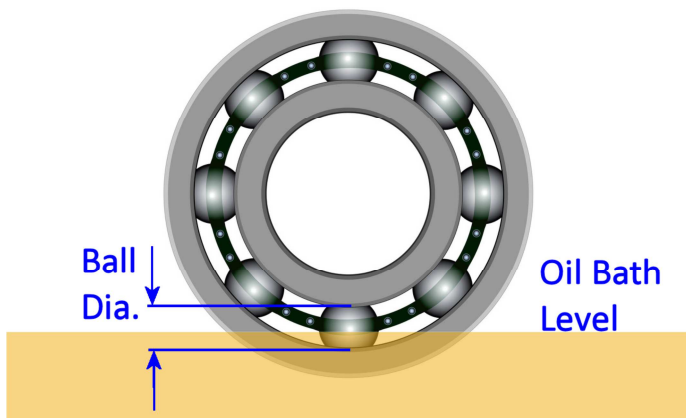

Figure 1: Oil bath lubrication showing a typical oil level

For 2 pole operation (3000 RPM and higher) and for larger bearings, many manufacturers utilize oil lifting lubrication via oil ring or oil slinger. The goal of these

arrangements is to have the normal oil level below the rolling element bearing (hence the lifting required), in order to minimize heat generation due to oil churning. This churning can easily account for  $> 50\%$  of the total heat generated in the bearing. A common rule is that when  $Nd_m$  exceeds 300,000, oil bath lubrication is no longer a good choice and oil lifting lubrication such as oil rings or slingers should be employed.

Oil mist lubrication is viewed by many as the “Gold Standard” in terms of providing optimum lubrication quantity, cleanliness and cooling to the rolling element bearings. The advantages of such arrangements are covered extensively in books such as *Oil Mist Lubrication: Practical Applications* (Bloch, H.P., Shamim, A., 1998) and will not be discussed further in this paper.

## INTRODUCTION

The purpose of this paper is to build upon existing papers on oil ring and oil slinger delivery. Specifically it encompasses the following goals:

- Side by side comparison between oil rings and slinger discs in a common arrangement
- Quantification of the effect of unfavorable housing angles on oiling performance
- Quantification of the effect of housing movement on oiling performance

By doing so it is hoped that the manufacturers and users of rolling element bearing arrangements will have a clearer understanding of the strengths and weaknesses of each design.

## Oil ring design considerations and prior art.

Oil rings are loose pieces that rest on the shaft under gravity and the bottom point of which dips into the oil sump. As the shaft rotates the oil ring is as driven to rotate, picking up oil from the sump, depositing oil on the shaft, throwing it against the inside of the housing and atomizing oil into a mist.

Because the oil ring is free to move, a significant range of motions is possible many of which are described in (Heshmat and Pinkus, 1984). These can be Oscillatory (pendulum), Conical and Translatory as shown in Figure 2. Additionally if the installation of the pump is not level or is ship based, the ring has a tendency to act under gravity to run downhill.

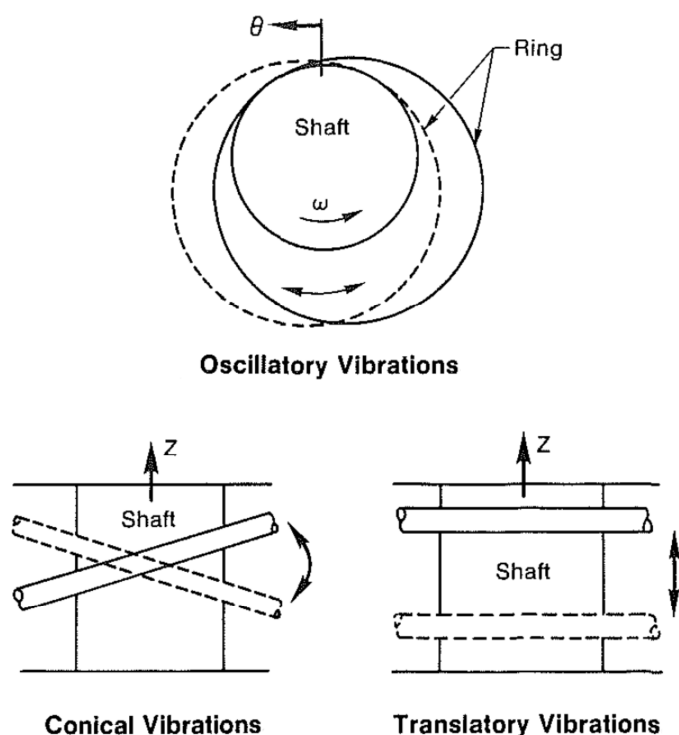

Figure 2: Oil ring motions (Heshmat and Pinkus, 1984)

Due to these movements the oil ring may interact with the fixed structures in the bearing assembly in an unfavorable way which can lead to a reduction in oil delivery together with oil ring and/or housing wear. There have been reported cases of extensive ring wear (Bloch and Budris 2010). For this reason modern oil rings designs tend to employ guides or carriers in order to better control the ring motion.

The equations governing oil ring operation were extensively defined by (Lemmon and Booser, 1960). There are three discrete modes of operation which are described below and shown in Figure 3:

- No-slip Drive which occurs at slow speeds where the oil ring is driven at a speed in direct proportion to the shaft speed.
- Partial-film Drive occurs when the ring starts to slip and a decreased driving force is provided by the partial oil film between the ring and the shaft. Depending on ring size there can be a significant slowdown in ring speed relative to the no-slip drive speed.
- Full-film Drive occurs with further shaft speed increases. The ring speed starts to increase again and is determined by the Reynolds numbers of the shaft and ring.

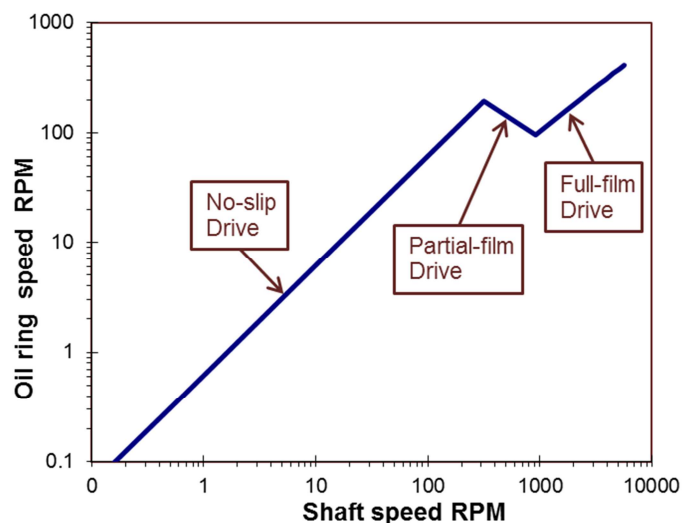

Figure 3: Oil ring operating regimes

Since most oil rings in pump bearing applications operate in Full-film Drive mode, it is this mode that the paper will focus on. Factors that can affect the oil ring speed include oil viscosity, ring submergence and ring mass.

A later paper (Heshmat and Pinkus, 1984), determined that the optimal ring shape for oil ring stability and oil delivery was a trapezoid. There was also a determination made of the “optimum” ring weight (for oil delivery) per unit of circumference as being  $\approx 24$  N/m (0.14 lb/in) although no data was presented to support this. No comparative oil ring wear testing results were presented although it was stated that “*the brass ring wears slightly less than the others*” (those others being bronze to SAE-660 and Muntz (60Cu-40Zn).

The significant aspect of both papers was that the testing was centered around the use of oil rings to feed a journal bearing setup. This makes it difficult to determine how applicable they would be to a modern oil ring arrangement used to feed oil to rolling element bearings via collection shelf geometry. Both papers also discounted the use of light weight (or non-metallic) rings as being suboptimum based around their lower measured oil delivery rates.

In a study on black oil formation in API 610 pump bearing housings (Bradshaw, 2000), the stability of a non-metallic oil ring was found to be superior to that of a bronze oil ring of similar geometry. Specifically it was stated that:

*“Test showed that the source of bronze in the oil was primarily due to the oil ring erratically hitting the bearing housing and bearing cap or wearing against the oil ring carrier. Varying the oil level did not eliminate this behavior....The nonmetallic ring ran in a more stable fashion*

*eliminating the erratic tracking and pendulum behavior seen with metallic rings and did not exhibit any wear during testing. It was concluded that oil viscosity exerts a greater damping influence over the low mass, nonmetallic ring than a metallic ring thereby effectively preventing the erratic motion and tracking from occurring.”*

While this comparison was made using a standard production rolling element bearing housing, there was no attempt made to measure and compare oil delivery rates for the different oil ring materials.

The authors are not aware of any paper where the effect on oil ring stability and oil delivery of housing inclination or pitching/rolling (such as might be encountered on a ship or FPSO based installation), are studied. This is a significant concern given that such installations are increasingly used in recovering oil from offshore wells.



Figure 4. FPSO in the Adriatic Sea, courtesy of Wikimedia [creativecommons.org](https://creativecommons.org)

### Oil Slinger design considerations and prior art

The oil slinger disc arrangement is simple to understand. A disc is mounted inside the bearing housing and is driven by the pump shaft. The disc outer edge is immersed some depth into the oil. As it rotates oil is lifted from the sump and thrown onto the inside of the housing. This also results in some atomization of the oil into a mist within the air space of the housing. Refer to Figures 5 and 6.

Since the disc is connected to the shaft, the speed of the disc is easily known. The disc is insensitive to vibration and housing inclination.

The design of the housing must be considered in advance when a rigid oil slinger is to be used. This is because the slinger cannot be larger than the opening in the bearing housing in order to allow assembly. This in turn means the oil level

must be controlled carefully unless oil bath operation is acceptable. See Figure 5 which shows an example of an arrangement with a small disc and the normal oil level such that the bearing elements are submerged.

In the past, two alternate designs have been proposed in order to circumvent the limitation of a rigid slinger disc.

One design employs a flexible slinger disc either made from an elastomer or with flexible metal petals. In both cases the flexibility of the disc allows a larger diameter disc than could otherwise be used. The disadvantage of a flexible disc is that it can move in unexpected ways during operation. This may occur if the disc is sited in close axial proximity to some internal structure within the bearing housing such that it is affected by the windage hitting this structure. In one test performed in the author's R&D facility, movement of the disc effectively blocked off oil to a bearing causing it to fail.

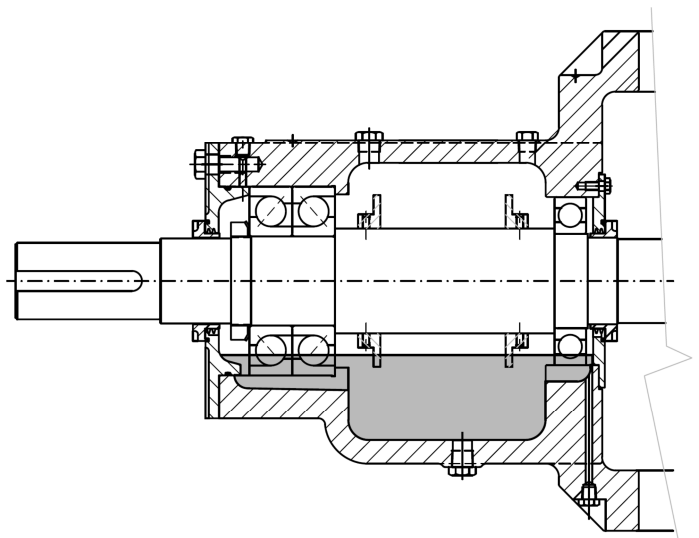

Figure 5: Bearing housing with small dual oil slinger discs operating as a mixed oil bath/oil slinger arrangement

A second alternate design is the use of a thrust bearing cartridge, (basically an additional component that allows a larger rigid disc to be assembled in place). See Figure 6. The disadvantage is the introduction of an additional component and set of tolerances to the overall assembly tolerance stackup. Given that API 610 (API 610 11<sup>th</sup> edition 6.10.1.8 b) precludes the use of bearing carriers (on shafts) for similar reasons, the acceptance of such an arrangement may not be universal among users.

When a cartridge arrangement is deployed, provision for feeding of oil to the outermost (Drive end) thrust bearing needs to be considered and included. Incorporating the required feed and drain-back features is rendered more complex in that

features must be incorporated in both the housing and the cartridge. The cartridge to housing assembly must be poka-yoke to prevent it being assembled with the oil feed passages out of position as this would lead to rapid bearing failure.

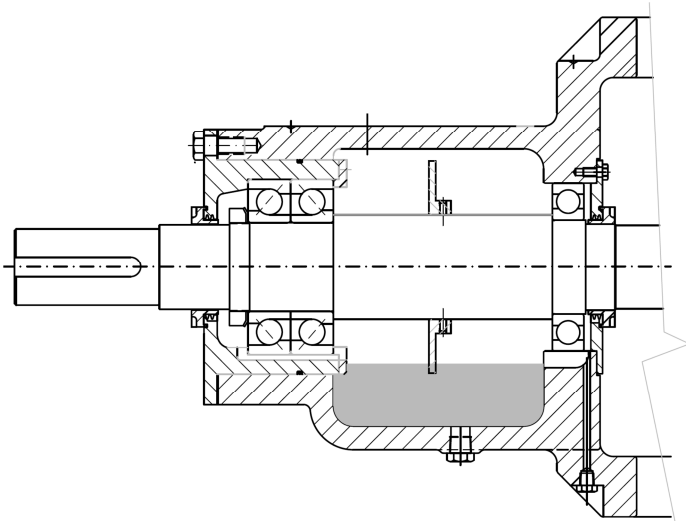

Figure 6: Example arrangement of a bearing housing with thrust end cartridge and large diameter oil slinger

The best attempt to describe the equations governing oil slinger operation was by (Ettles et al, 1979). In this paper a slinger disc was operated over a range of speeds with different oil scrapers, oil immersions, oil viscosities and casing clearances. From this an equation was developed that defined the oil delivery rate.

A further important effect was noted which was characterized as the flinger “critical speed” This was due to the windage of the disc blowing on the oil sump surface, locally displacing the oil which in turn impeded oil pickup. The effect increased at higher speeds to the point at which when the slinger speed was approximately 2.5x critical speed, oil delivery went to zero.

Since this slinger disc was partly enclosed by a close fitting casing and utilized a scraper, the relevance of this paper to a slinger disc operating in the open inside a bearing housing with no close clearances was unclear.

Other papers that existed for slingers employed very large slow running discs (Gardner, 1977) or utilized a hollow disc and internal scoop (Kaufman et al, 1978) and hence also had limited relevance to the smaller, open high speed arrangement of interest in this study.

### TEST RIG SETUP

The test rig is a custom design specifically for the observation and measurement of oil delivery. The main

features of the test rig are shown in Figure 7a, 7b, 7c and 7d. Internally the test rig is a close facsimile of half of the geometry associated with bearing oil delivery for the company’s OH2 model line, specifically the SX size. This arrangement uses cast sloping troughs to capture the oil thrown by the oil delivery device (normally an oil ring) and deliver it to both the radial and thrust bearings. In the test rig arrangement the sloping trough is machined and attached to the housing to allow adjustment if desired. The output of the trough is piped through the front of the test rig into the collection/measurement container.

The test rig is equipped with a viewing window and internal lighting to allow close observation of the oil delivery and to ensure that the oil level internal to the housing remains at the desired level during testing.

Externally the test rig is mounted on a platform that can pivot parallel to the shaft axis and also perpendicular to it. These dual pivots represent the pitch and roll axis of a ship or FPSO. Each pivot axis is controlled via a separate motor driven variable speed gearbox. This allows the pitch and roll periods to be adjusted as required. The test rig was capable of creating an angle of  $\pm 8^\circ$  on the pivot parallel with the shaft axis and an angle of  $\pm 4^\circ$  on the pivot perpendicular with the shaft axis.

Drive of the oil ring or oil flinger is via a 3 phase AC motor linked to a VFD. This allowed precise control of the speed from 1000 up to 7200 RPM.

Measurement of the oil delivery rate was made using a 100 ml measurement container together with a stopwatch. The quantity was selected to ensure a long enough delivery period and quantity in order to minimize measurement errors. Measurement of the oil ring speed was performed with a tripod mounted laser tachometer targeting a strip of reflective tape bonded to the side of the oil ring.

The relevant details of the test rig setup and SX bearing arrangement are as follows:

Test rig speed range	1000 to 7200 RPM
Test rig pitch angle range	$\pm 4^\circ$
Test rig roll angle range	$\pm 8^\circ$
Test rig oil ring materials	Bismuth Bronze (Pb Free) Phenolic grade CE
Oil ring dimensions (see also Figure 7c)	4.250” (108mm) ID 4.750” (120.7mm) OD 0.31” (7.9mm) width
Oil slinger disc dimensions	4.325” (109.9mm) OD 0.19” (4.8mm) width

SX thrust bearings	7312
SX radial bearing	6212
SX allowable speed range	1000 to 4000 RPM
SX cooling	Finned free convection or Forced convection fan or Fin tube cooling insert
SX lubrication method	Dual oil rings with ISO VG 68 oil

The expected error of the measurement devices is:

Parameter	Expected error
Oil volume	$\pm 1\text{mL}$
Time	$\pm 1$ second
Rotational speed (oil ring)	$\pm 25$ RPM*
Rotational speed (shaft, flinger disc)	$\pm 3$ RPM

\*primarily caused by variation in readings due to lubricant splashing

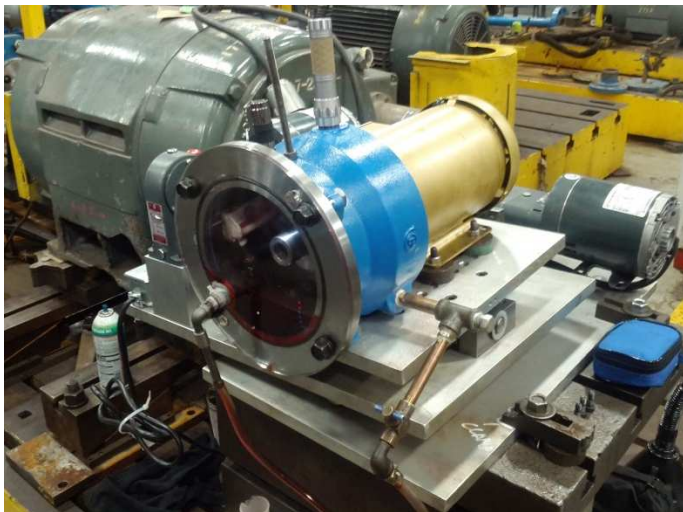

Figure 7a: Assembly of the Test Rig during roll/pitch testing



Figure 7b: End view of the Test Rig during roll/pitch testing

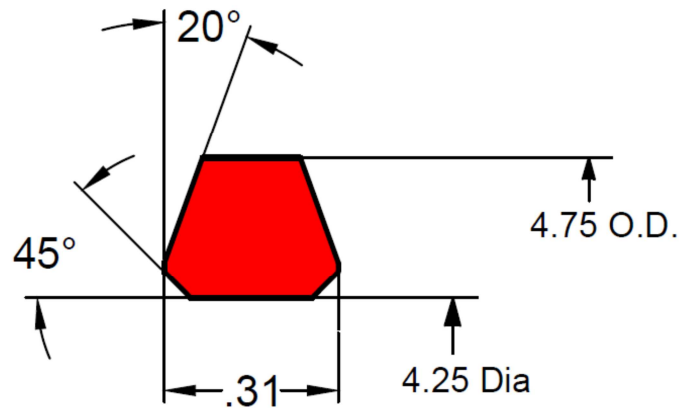

Figure 7c: End view of the Test Rig during roll/pitch testing

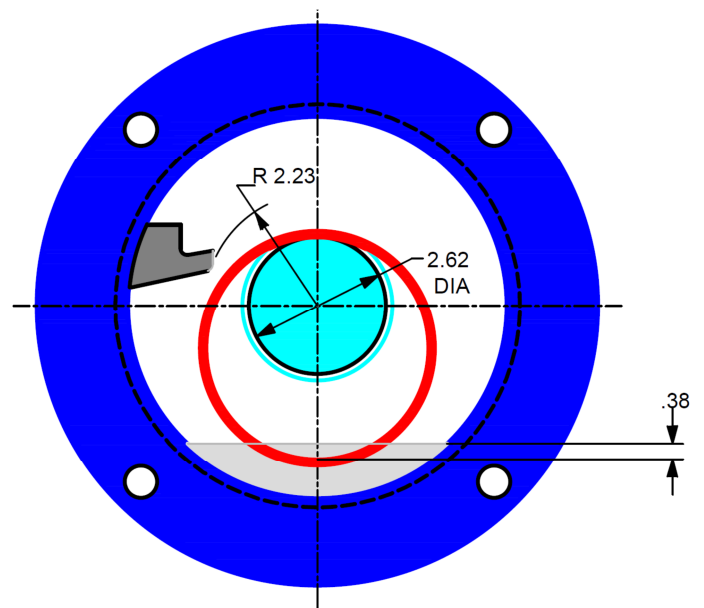

Figure 7d: Dimensional details of the Test Rig

The oil used for all testing was Castrol Transmax full synthetic ATF. This was selected because the oil viscosity at 74°F (23°C) (the temperature that the R&D building was controlled to), was  $\approx 47$  cSt. This represented a typical viscosity expected to be present in a VG68 oil under good bearing operating conditions.

For all of the testing described in this paper, the sense of rotation was CCW. Tests were performed with CW rotation and it was found that under any speed or set of conditions, no oil flow could be established as the collection trough effectively prevented any oil being deposited. The conclusion from this is that the collection trough needs to be engineered for the specific rotation desired and if bi directional rotation is required, oil collection troughs on both sides of the housing are necessary.

## ESTABLISHMENT OF MINIMUM OIL REQUIREMENT

An important question related to oil delivery and rolling element bearings is “*What is the minimum oil delivery that is consistent with reliable bearing operation?*”. After review of the existing literature a decision was made to utilize the guidelines established by publication TPI 176 (Schaeffler Technologies INA FAG 2013). Figure 18 of TPI 176 provides guidance regarding oil quantity for circulated lubrication. This is reproduced in part in Figure 8 below. The line shows the minimum volume flow for bearings where the oil performs no cooling up to  $Nd_m = 500,000$ .

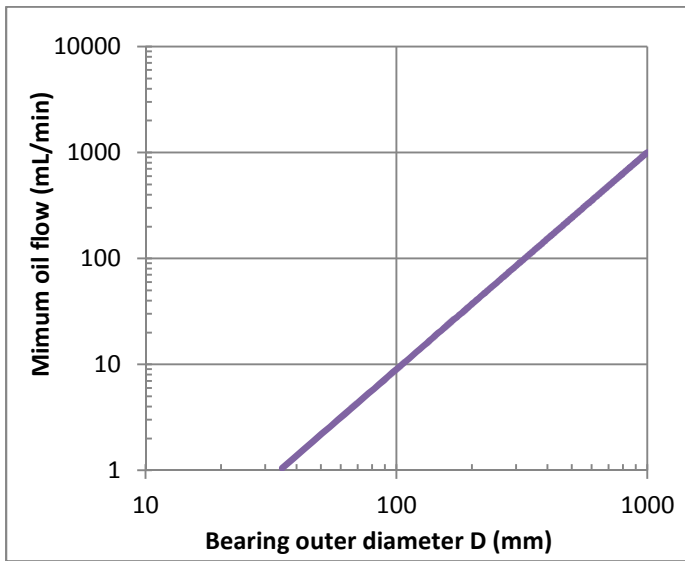

Figure 8: Minimum circulated oil flow from TPI 176 Fig 18 with  $Nd_m = 500,000$ .

Since the SX bearing frame utilizes 7312 angular contact bearings,  $D$  is 5.12” (130mm). From this the minimum oil flow is 15.4 mL/min. Since this is for  $Nd_m \leq 500,000$ , the minimum oil flow was adjusted up or down given that  $Nd_m = 500,000$  for a 7312 bearing occurs at 5263 RPM.

It is certainly possible to lubricate the bearing with less oil than this. Once through systems such as oil mist or oil spot lubrication utilize oil deliveries that are significantly lower (in the range of 0.04 mL/min for a 7312 bearing pair at 3600 RPM). However these are once through systems or “throwaway” lubrication where the oil is discarded after it has passed through the bearing. They also require a  $\kappa$  ratio in the range of 8 to 10, meaning that a more viscous oil (than the customary VG68), is necessary. Hence in the author’s opinion these low volume flow rates for such systems can’t be applied to small self-contained sump oil lubricated arrangements.

## BASELINE TESTING

The test rig was setup with a 0.38” (9.5mm) oil submergence and level stationary conditions. This represents normal conditions in a land based installation.

Measurement of oil delivery was then made at a number of speeds from 1000 RPM to 6000 RPM and is shown in Figure. There are significant differences between how oil delivery varies with speed. The oil ring delivery is lower at low shaft RPM, increasing to peak value beyond which the delivery rate declines. The slinger disc had the highest delivery at low shaft RPM and declined continually up to the highest RPM.

Based on the minimum lubrication delivery line established previously, it can be seen that the slinger disc oil delivery was insufficient beyond around 2100 RPM. The oil ring delivery from the bronze ring was sufficient over the full range of speeds run. The nonmetallic ring fell slightly below the minimum delivery at 1000 and 1200 RPM and again at 4100 RPM, exhibiting a narrower range of acceptable oil delivery. One possible reason for this is that the nonmetallic ring tended to displace towards the trough due to its lighter weight. This created additional drag and contributed to the slower ring speeds shown in Figure 13b.

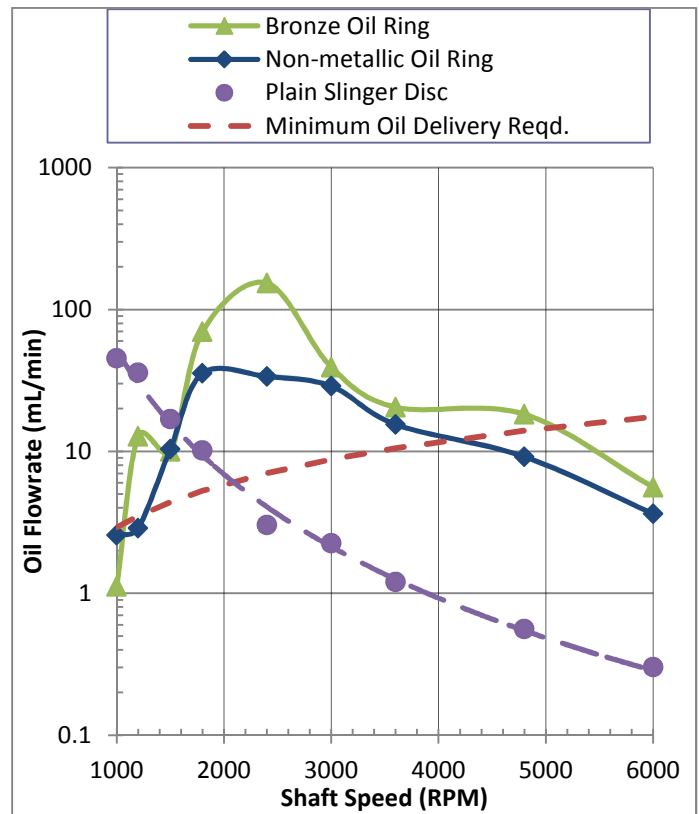

Figure 9: Baseline oil delivery test, level, stationary 0.38” (9.5mm) ring submergence.

The reason for the continuous drop in slinger disc delivery was observed to be linked to the trajectory of the oil from the disc. As the shaft speed increased, oil was thrown off the disc closer and closer to the point at which the disc left the oil surface. See Figure 10. This progressively reduced the amount of oil available to be later deposited onto the top of the housing or into the collection trough. Additionally the windage of the disc as observed by Ettles (Ettles et al, 1979), was a likely contributing factor.

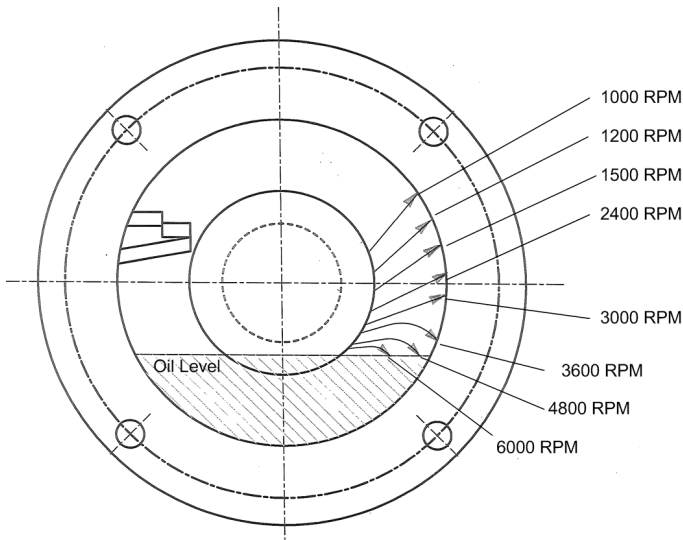

Figure 10: Trajectory of oil from the plain flinger disc

**TESTING WITH VARYING SUBMERGENCE**

The test rig was setup with a range of oil submergence from 0.13” (3.2mm) to 1.13” (28.6mm) and level stationary conditions. The purpose was to quantify the effect of under or overfilling the bearing housing in a land based installation.

It should be noted that earlier versions of API 610 (introduced in the 8<sup>th</sup> edition and removed in the 9<sup>th</sup> edition), called for a 0.12” to 0.25” (3mm to 6.4mm) submergence. This was later dropped as the margin between a design working and not picking up any oil became very small. Testing outlined in this paper indicates that dropping this requirement was a good decision.

Measurement of oil delivery was then made at a number of speeds from 1000 RPM to 6000 RPM and is shown in Figures 12a and 12b.

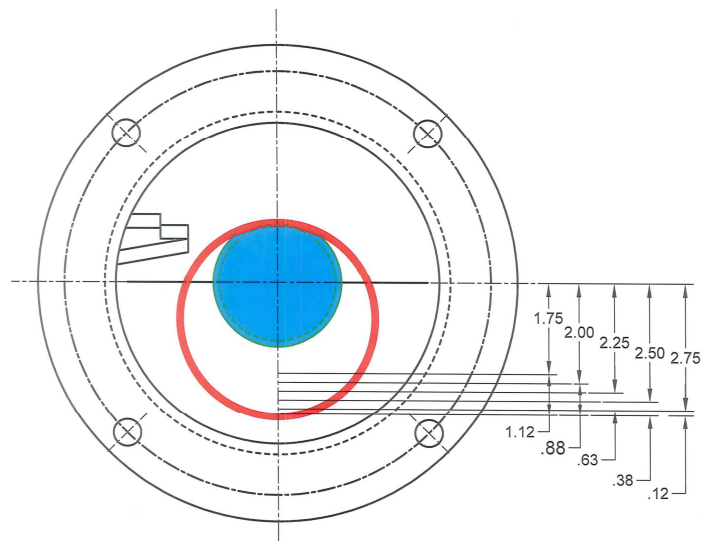

Figure 11: Arrangement showing differing submergence with an oil ring.

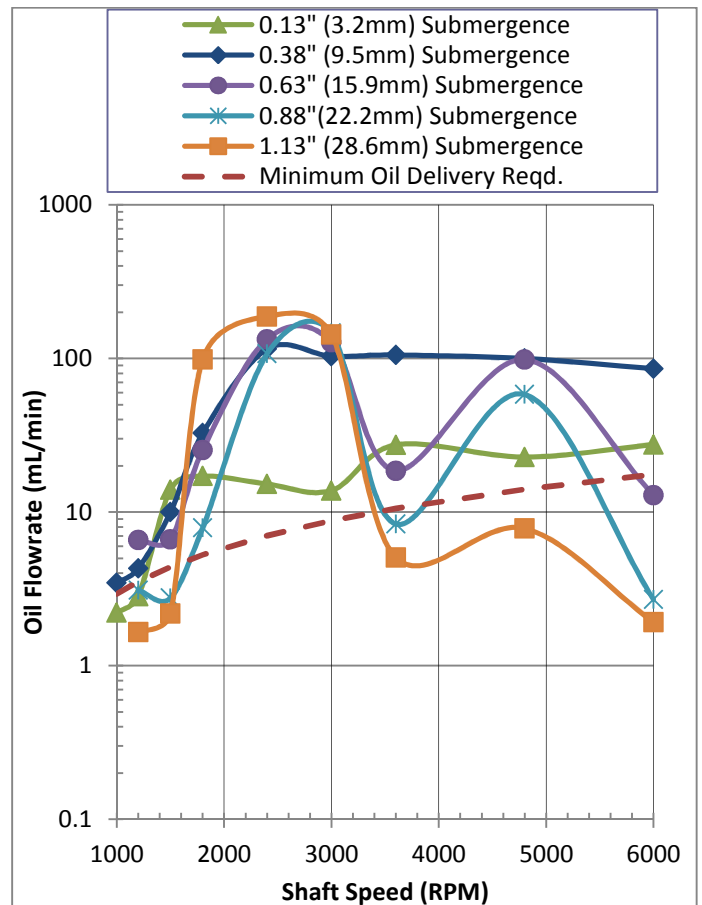

Figure 12a: Bronze ring oil delivery with varying submergence.



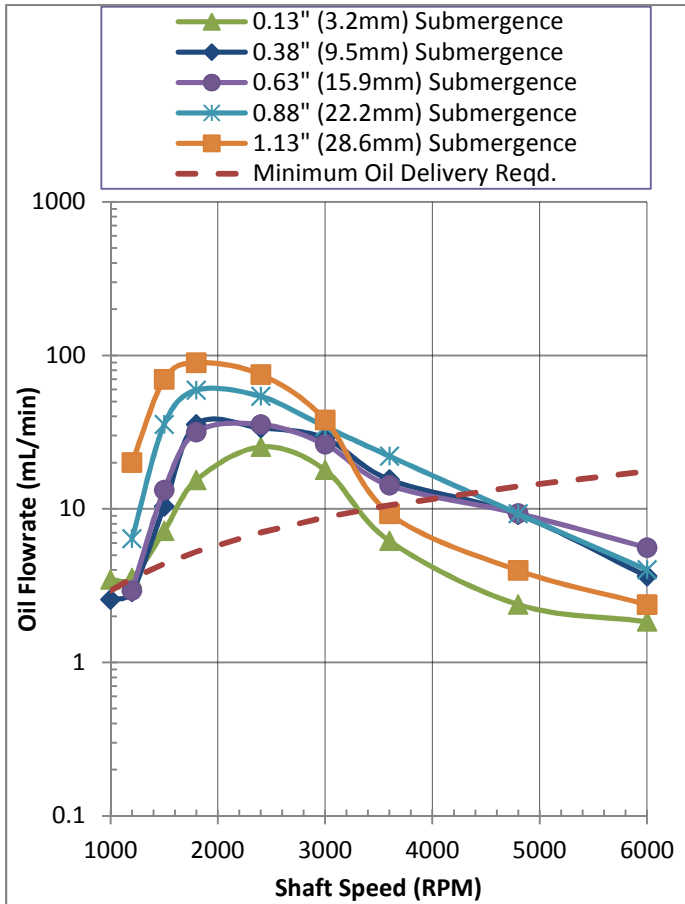

Figure 12b: Non-metallic ring oil delivery with varying submergence.

The results for the bronze oil ring show significantly more variability than for the nonmetallic oil ring. This is related to the stability of the ring particularly at high speeds and will be discussed later.

In general while the oil rings delivered sufficient oil over a wide range of submergences and speeds, increasing submergence was associated with reduced oil delivery particularly at higher speeds. Reducing submergence below 0.38" (9.5mm) was not beneficial in terms of oil delivery.

The speeds of the oil rings was also measured and is shown in Figures 13a and 13b. In general the nonmetallic oil ring operated with ring speeds that were 61% to 74% of the speed attained by the bronze oil ring. Since the speed of the ring correlates loosely with oil delivery, the slower speeds were likely part of the reason for the lower oil delivery from the nonmetallic ring.

For the oil slinger disc it was found that small changes in immersion depth yielded large changes in oil delivery rate. The immersion depth was increased from 0.38" (9.5mm) in 0.125"

(3.2mm) increments. The results are shown in Figure 14. At 3600 RPM, changing the oil level from 0.5" (12.7mm) to 0.63" (15.9mm) resulted in a 5x increase in oil delivery. This indicates that establishing and maintaining adequate submergence is key to a successful oil slinger disc design.

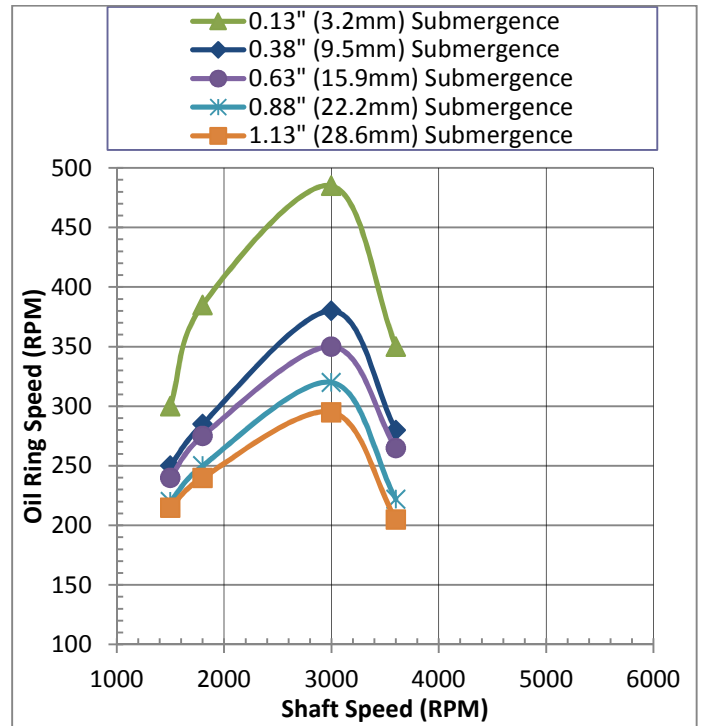

Figure 13a: Bronze ring oil speed with varying submergence.

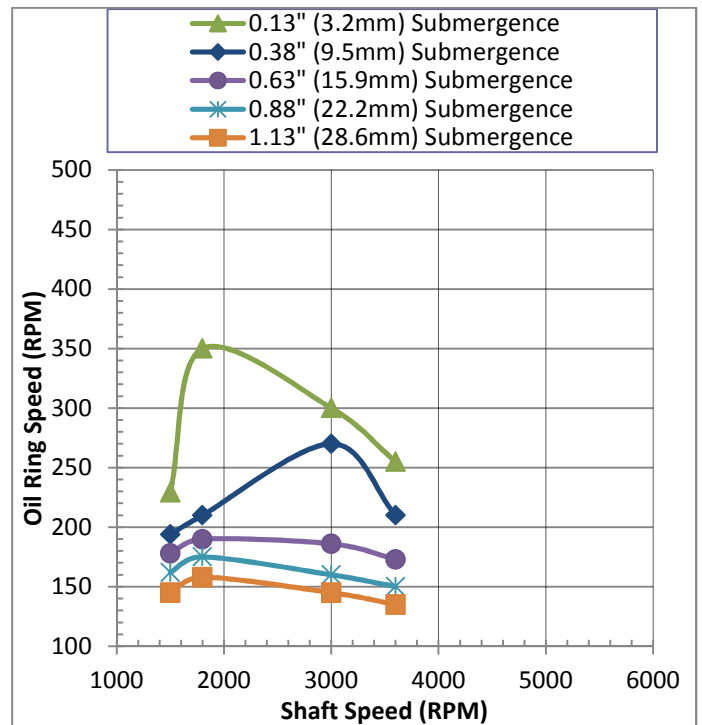

Figure 13b: Non-metallic ring oil speed with varying submergence.

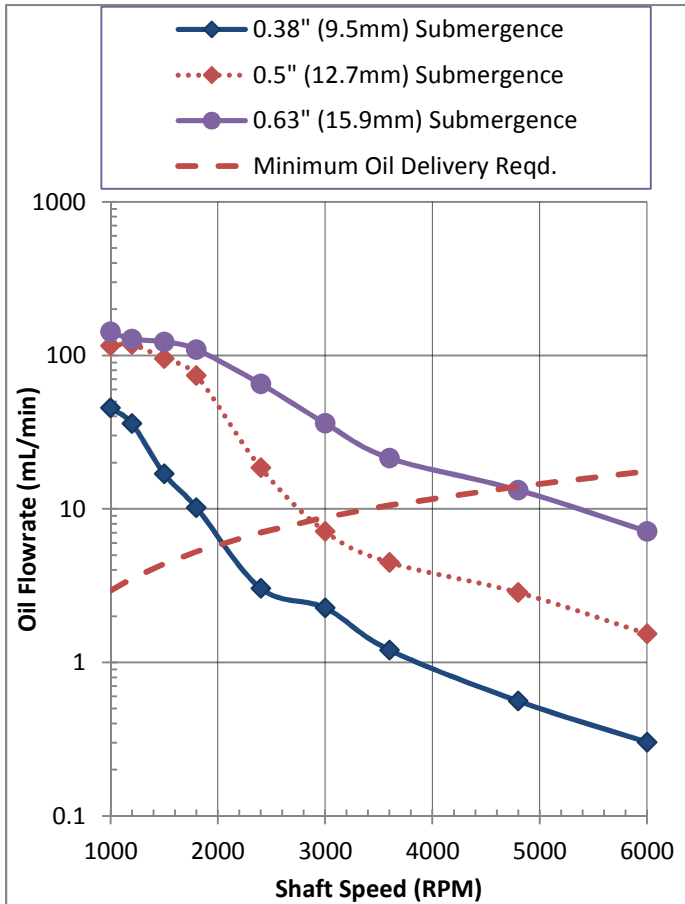

Figure 14: Oil slinger disc oil delivery with varying submergence.

### TESTING WITH PITCH & ROLL MOTIONS

The housing motion was set such that it experienced  $\pm 4^\circ$  pitch and  $\pm 8^\circ$  roll. See Figure 15 for details of the setup. The period of both the pitch and roll motions was 15 seconds. This represents normal conditions for the bearing housing on a FPSO based installation in the Southern Atlantic.

Measurement of oil delivery was then made at a number of speeds from 1000 RPM to 6000 RPM. Refer to Figure 16.

Compared to the baseline test, both oil rings delivered more oil at low shaft speeds in this pitching/rolling arrangement. This was because the oil delivery under favorable angles of pitch or roll greatly outweighed the lower oil delivery at unfavorable angles.

The flinger disc had the highest delivery at low shaft RPM and declined continually up to the highest RPM. At a 0.63" (15.9mm) submergence acceptable oil delivery was achieved up to 4200 RPM. If the flinger disc submergence was reduced to 0.38" (9.5mm), oil delivery was acceptable only up to 2100 RPM, a similar result to the stationary testing.

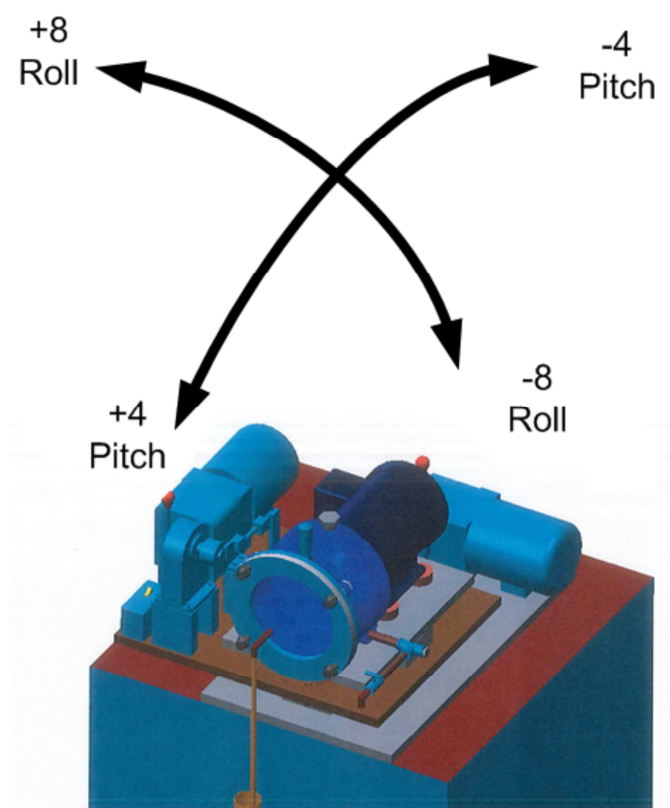

Figure 15: Test rig pitch and roll angles

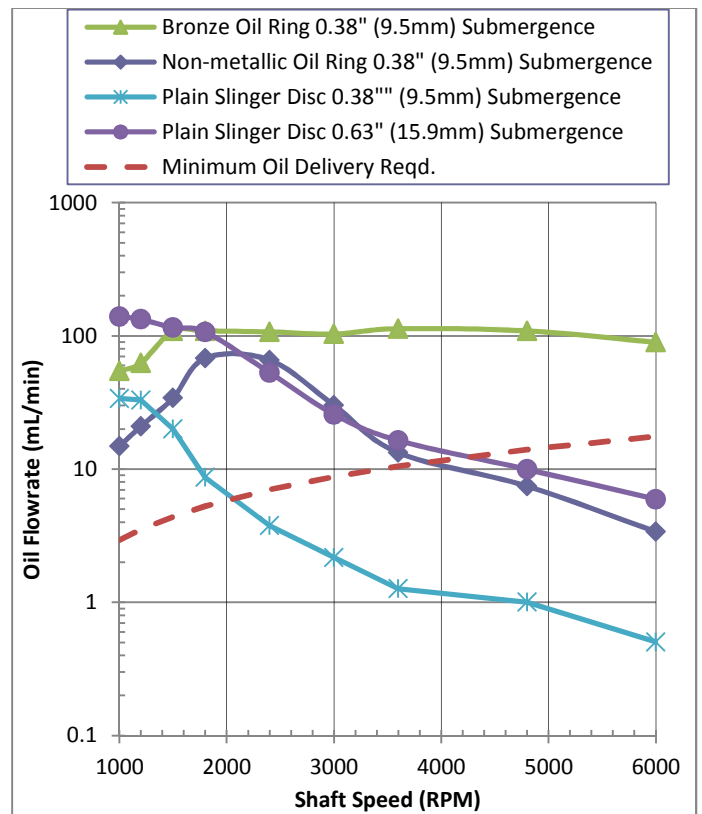

Figure 16: Oil delivery testing with the test rig in motion - active pitch of  $\pm 4^\circ$  and active roll of  $\pm 8^\circ$  with a 15 sec. period

### TESTING WITH ADVERSE HOUSING ANGLES

The housing was set stationary with  $-8^\circ$  roll and  $-4^\circ$  pitch angles. The intent was to simulate worst case angles as might occur in an accident where the ship or FPSO was damaged and unable to remain level in the water. With these angles, the oil tends to run off of the collection trough, reducing residence time and oil delivery.

Measurement of oil delivery was then made at a number of speeds from 1000 RPM to 6000 RPM. Refer to Figure 17.

Both oil rings delivered some oil under all speeds. However the delivery was less than the minimum delivery criteria for a circulating system. In practice this means that while the bearings would be lubricated to some extent, operation for long periods in such a configuration would potentially reduce the bearing life. Considering these adverse angles would only occur infrequently, this *may* be tolerable.

The oil slinger at 0.38" (9.5mm) submergence delivered sufficient oil at lower speeds, falling below the minimum required at 1500 RPM. At 3000 RPM and higher, oil delivery became basically zero. With a 0.63" (15.9mm) flinger disc submergence, oil delivery was better than the oil rings below 2000 RPM (delivering above the minimum required), but at 2 pole speeds delivered less than either oil ring.

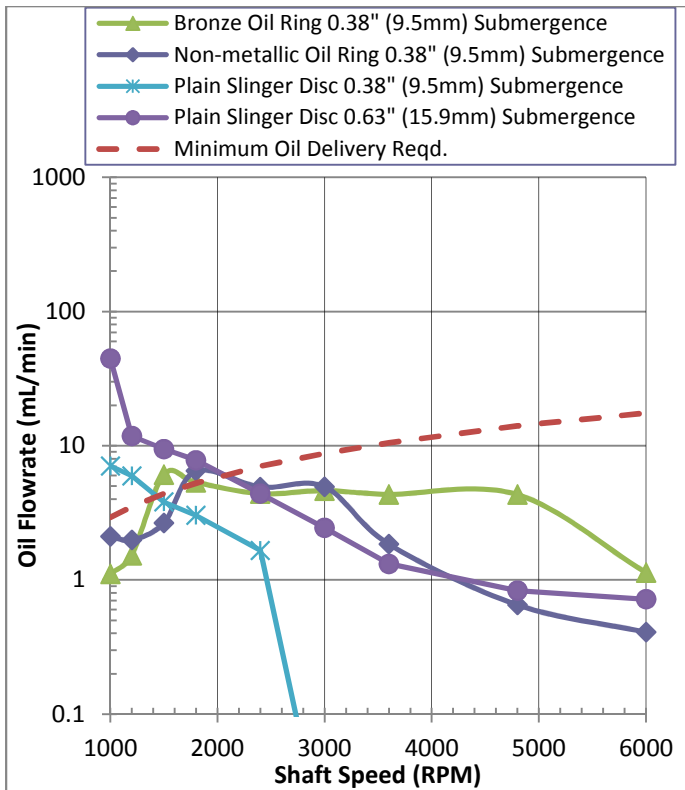

Figure 17: Oil delivery testing with a stationary test rig and adverse housing angles ( $-4^\circ$  pitch and  $-8^\circ$  roll, see Figure 15).

As noted previously, what constitutes acceptable oil delivery for a short term emergency operation needs to be reviewed in light of the capabilities of each oil delivery method.

### ASSESSMENT OF OIL RING STABILITY

Any assessment of oil ring stability is always going to be somewhat subjective based on the observer and the language used to describe the motion. For this test a 60 second video of each oil ring was and speed combination was taken. A panel of six people watched the video and individually ranked the oil ring stability on a scale of 1 to 10, where 1 = very unstable and 10 = perfectly still. If contact was noted between the oil ring guide or the bearing housing and the oil ring, we noted the number of times per minute that contact occurred. The results are graphed in Figure 18 below.

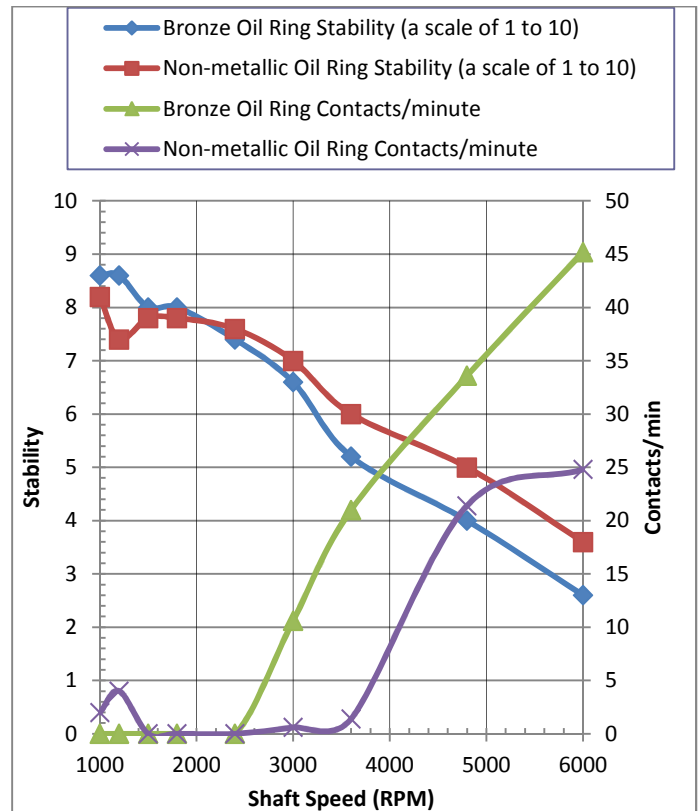

Figure 18: Oil ring stability and rate of contact

It was found that the bronze oil ring was less stable particularly at 2 pole speeds and higher. Additionally the number of observed contacts per minute rose continuously from 2400 RPM. In contrast the non-metallic ring contacts started to rise only above 2 pole speeds and the number of contacts remained less.

## OIL RING WEAR

Each oil ring was run for 168 hours at 3600 RPM with the normal 0.38" (9.5mm) oil submergence. The weight of each ring was measured before and after the test using a jewelry scale with a 0.01 gram resolution.

No reduction in the weight of either ring was detected. The bronze ring did exhibit polishing on the inside diameter of the ring where it contacted the shaft. See Figure 19. It was concluded that if wear was occurring, the rate was too small to measure in the time allotted for the test.

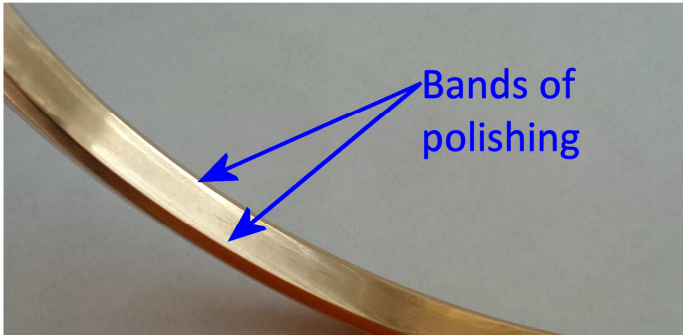

Figure 19: Bronze oil ring after wear testing

## OUT OF ROUND OIL RINGS

Within the available literature, there is some disagreement over what degree of out of roundness is acceptable for an oil ring.

(Lemmon and Booser, 1960) performed testing with a 16.5" (419mm) diameter ring with 6% out of roundness-forming an ellipse with a major axis of 17" (432mm) and a minor axis of 16" (406mm). They reported that the oil delivery to be 80% of the value obtained from a ring with 0.07% out of round. They further stated (although no supporting test data is presented), that :

*"Out-of-roundness up to 2 per cent of the ring diameter has no appreciable effect on ring speed or oil delivery"*

In contrast (Bloch 2013), referencing a 1957 book by Wilcock and Booser, recommends concentricity limit of 0.002" (0.05mm). This limit is then contrasted with a 2009 example where oil rings "exceeded the 0.002-inch (0.05 mm) allowable out-of-roundness tolerances by a factor of 30". The stated limit is not linked to any specific size of oil ring.

Concentricity and roundness (circularity) are two different things (the reader should refer to ANSI Y14.5 for the definitions), but the guidance implies that 0.002" (0.05mm) is the limit to be used in both measurements.

In order to evaluate the effect of out of roundness on oil ring delivery, the authors elected to test an oil ring with 2% out of roundness. Since the oil ring utilized had an inside diameter of 4.063" (103.2mm) a 2% out of roundness forms an ellipse with a major axis of 4.104" (104.2mm) and a minor axis of 4.022" (102.2mm).

The bronze oil ring was utilized for this test as it was found to be impossible to achieve the required permanent yield with the non-metallic ring (it would either spring back to its original shape or would break when very large deformations were applied). The testing was run for two different submergence levels and a range of speeds. The results are presented in Figure 20.

In general it can be said that oil ring out roundness helps with oil delivery at low speeds (below 2000 RPM), and has mixed results at high speeds. Oil delivery was sufficient at all the speeds test up to 5000 RPM. At higher speeds of operation the effect of the out of roundness was more noticeable in the movement of the oil ring, although overall stability was similar to the normal ring.

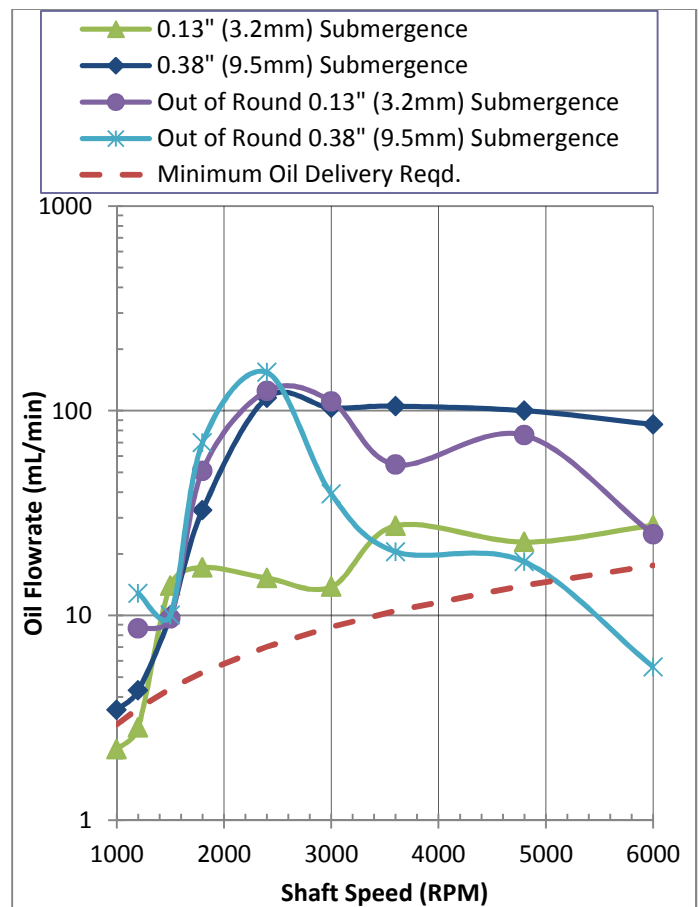

Figure 20: Oil delivery testing with the out of round oil ring overlaid with the results for a normal oil ring

## DISCUSSION

### COMPARISON OF OIL RING RESULTS WITH PREVIOUS STUDIES

Lemmon & Booser (Lemmon and Booser, 1960), provided a range of formulae to define the operational behavior of an oil ring. For the geometry and speeds tested in this paper, the oil ring was operating in “Full-film Drive” as defined in their paper. For a 10% submergence and metric units, the equation governing oil ring speed was defined as:

$$N_r = 0.26 \frac{\nu^{0.2}}{D_r^2} (Nd_s^2)^{0.8}$$

When the oil ring speed predicted by this formula (see Figure 21), is compared to the test results three observations can be made

- The non-metallic oil ring speed deviates significantly from the prediction
- The bronze oil ring speed agrees with the prediction at slower speeds but deviates at higher speeds
- Oil ring speed for both materials declines at higher speeds contrary to the prediction by the formula

The last finding merits further analysis and testing to determine the factors influencing this behavior.

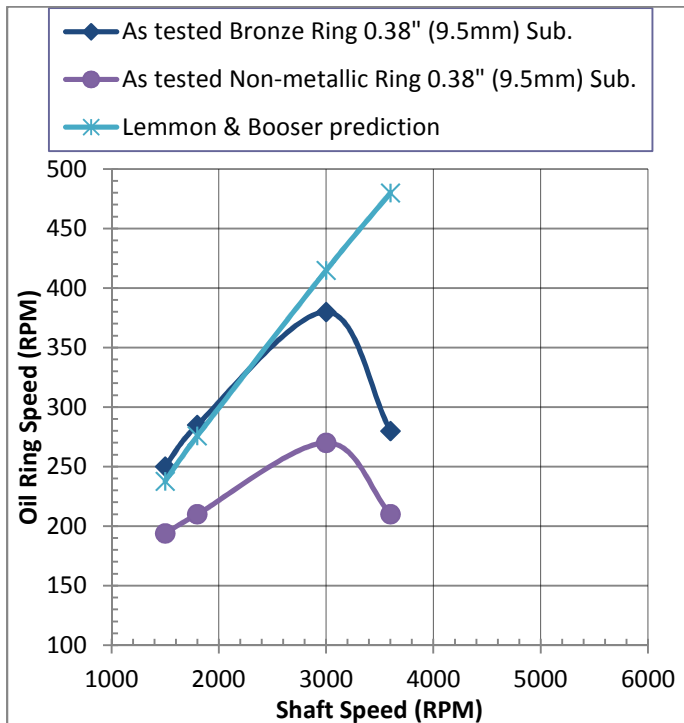

Figure 21: Oil delivery comparison with theory.

Similar behavior was not observed by Lemmon & Booser (Lemmon and Booser, 1960), possibly due to their testing being limited to shaft speeds below 3600 RPM. Heshmat & Pinkus (Heshmat and Pinkus, 1984), did observe some decline in oil ring speed beyond a certain shaft speed. However there was no attempt made to quantify the factors that caused this.

Due to resource constraints the authors were unable to make a more detailed study of the phenomenon and this will necessarily be the subject for a future paper.

### COMPARISON OF FLINGER DISC RESULTS WITH PREVIOUS STUDIES

From the work by Ettles (Ettles et al, 1979), a correlation was found linking oil delivery to a number of variables. The oil delivery from the disc was defined as:

$$Q = \frac{60 * 300UHL^{0.5}}{\mu^{0.25}}$$

The data obtained from this testing was checked against this formula however an acceptable correlation could not be obtained. This is not unexpected given the significant differences between the geometries of the test rigs.

The Ettles formula was fitted to the test results and based on this the following formula obtained:

$$Q = \frac{8.2 * 10^{-18} * U^{-2.8} H^{5.9} L^{0.5}}{\mu^{0.25}}$$

Note the sensitivity to submergence reflected in the H to the 6<sup>th</sup> power term in the equation. The applicability of this equation to other bearing housing geometries would need to be verified by testing and hence it should be used with caution when the design differs significantly from the test rig used here.

## SUMMARY AND CONCLUSIONS

The oil slinger had the best oil delivery at slow speeds. Its high speed delivery was very sensitive to oil submergence. Achieving and maintaining sufficient oil submergence requires that the bearing design and oil level control be considered carefully. Specifically since a large diameter slinger disc would be necessary to achieve the submergence goals, deployment of such a disc in the housing would likely require a cartridge arrangement or another method of installing a larger diameter slinger disc.

Out of roundness of the oil ring up to 2% could affect oil delivery in either a positive or negative way depending on submergence, although oil delivery was found to be sufficient up to 5000 RPM for the scenarios tested. Since a 2% out of roundness translates to 0.082" (2.1mm) for the ring tested, it would be reasonable to conclude that a ring manufactured to an out of roundness limit of 0.1% of the ring diameter would perform acceptably.

The non-metallic ring was slower running, delivering less oil than the bronze ring, but is stable over a wider speed range. Given that this ring can be made from bearing materials that protect against incidental contact, it would suggest that this is a better choice for the lubrication of bearings in high speed (> 3600 RPM) operation provided the minimum oil delivery requirements can be met.

The bronze oil ring ran faster than the non-metallic oil ring for a given shaft speed which meant it delivered sufficient oil over a wider speed range. However it was more unstable at higher speeds.

Both oil ring materials can deliver sufficient oil quantities over wide range of submergences and speeds.

No wear was measurable on either oil ring as the result of testing. Experience with this specific housing oil delivery design (which has been in production for 19 years) is that with correct design provisions, oil ring wear is not a concern.

Testing shows that a correctly designed oil lifting system can provide adequate lubrication in FPSO or ship based installations. Given that it is difficult to predict oil delivery of a specific housing design, testing to validate sufficient oil delivery is strongly recommended. (The housing design and trough arrangement used in this paper had been evolved over many years as a consequence of such physical testing).

## NOMENCLATURE

FPSO	= Floating Production Storage & Offloading vessel
API	= American Petroleum Institute
d	= rolling element bearing bore (mm)
$d_s$	= shaft diameter at oil ring (m)
$d_m$	= rolling element bearing mean diameter $(d+D)/2$
D	= rolling element bearing outside diameter (mm)
$D_r$	= oil ring inner diameter (m)
H	= Submergence of ring or disc into the oil (m)
L	= effective width of the disc (m)
N	= shaft speed (RPM)
$Nd_m$	= the product of the shaft speed in RPM * the mean bearing diameter in mm (RPM*mm)
$N_r$	= Oil ring speed (RPM)
U	= disc peripheral speed (m/s)
Q	= oil delivery (mL/min)
$\nu$	=oil kinematic viscosity (cSt)
$\nu_1$	=minimum oil viscosity required by the bearing (cSt)
$\kappa$	= the ratio of $\nu/\nu_1$
$\mu$	=oil dynamic viscosity (cP)

## REFERENCES

1. Bloch, H.P., Shamim, A., *Oil Mist Lubrication: Practical Applications, 1998*
2. Heshmat, H., Pinkus O., *Experimental Study of Stable High-Speed Oil Rings, Transactions of ASME, 1984*
3. Bloch, H.P., Budris, A., *Pump User's Handbook-Life Extension 3<sup>rd</sup> Edition, 2010*
4. Lemmon, D.C., Booser E.R., *Bearing Oil-Ring Performance, ASME Journal of Basic Engineering, 1960*
5. Bradshaw, S., *Investigations into the contamination of lubricating oil in rolling element pump bearing assemblies, Proceedings of the 17<sup>th</sup> International Pump Users Symposium, 2000*
6. Ettles C.M.MC C., Adamson W.R., Yiallourous M., *Some Characteristics of the Disk-Scraper Oil-Feed Mechanism, Transactions of ASLE, 1979*
7. Gardner W.W., *Bearing Oil Delivery by Disk-Scraper Means, Transactions of ASME 1977*
8. Kaufman H.N., Szeri A.Z., Raimondi A.A., *Centrifugal Disk-Lubricated Bearing, Transactions of ASLE, 1978*
9. Schaeffler Technologies INA FAG, *Lubrication of Rolling Bearings TPI 176, 2013*
10. Bloch, HP., *Breaking the Cycle of Pump Repairs, Proceedings of the 29<sup>th</sup> International Pump Users Symposium, 2013*

## ACKNOWLEDGEMENTS

Special thanks to Cody Arliss for supporting the test rig and helping with the many hours of testing required.