

esting case, since it shows how a multiple twin of a monoclinic crystal may simulate an isometric crystal (dodecahedron).

Compound crystals in which twinning exists in accordance with two laws at once are not of common occurrence; an excellent example is afforded by staurolite, Fig. 441. They have also been observed with albite, orthoclase, and in other cases.

**242. Secondary Twinning.** — When there is reason to believe that the twinning has been produced subsequently to the original formation of the crystal, or crystalline mass, as, for example, by pressure, it is said to be *secondary*. Thus the calcite grains of a crystalline limestone often show such secondary twinning lamellæ. The same are occasionally observed ( $\parallel c, 001$ ) in pyroxene crystals. Further, the polysynthetic twinning of the triclinic feldspars is often secondary in origin. This subject is further discussed on a later page, where it is also explained that in certain cases twinning may be produced artificially in a crystal individual — *e.g.*, in calcite (see Art. 282).

EXAMPLES OF IMPORTANT METHODS OF TWINNING

**243. Isometric System.** — With few exceptions the twins of the normal class of this system are of one kind, the twinning-axis an octahedral axis, and the twinning-plane consequently parallel to an *octahedral face*; in most cases, also, the latter coincides with the composition-plane. Fig. 388, p. 161,\*

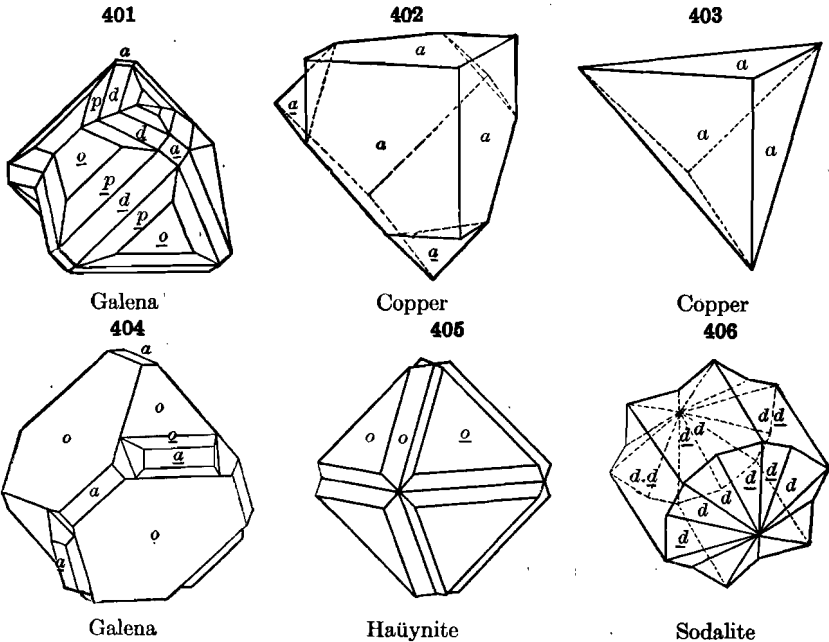

shows this kind as applied to the simple octahedron; it is especially common with the spinel group of minerals, and is hence called in general a *spinel-twin*.

\* It will be noted that here and elsewhere the letters used to designate the faces on the twinned parts of crystals are distinguished by a subscript line.

Fig. 401 is a similar more complex form; Fig. 402 shows a cube twinned by this method, and Fig. 403 represents the same form but shortened in the direction of the octahedral axis, and hence having the anomalous aspect of a triangular pyramid. All these cases are contact-twins.

Penetration-twins, following the same law, are also common. A simple case of fluorite is shown in Fig. 391, p. 163; Fig. 404 shows one of galena; Fig. 405 is a repeated octahedral twin of haüynite, and Fig. 406 a dodecahedral twin of sodalite.

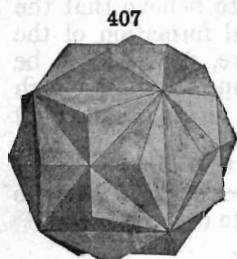

407  
Pyrite

244. In the *pyritohedral class* of the isometric system penetration-twins of the type shown in Fig. 407 are common (this form of pyrite is often called the *iron cross*). Here the cubic axis is the twinning-axis, and obviously such a twin is impossible in the normal class.

Figs. 408 and 409 show analogous forms with parallel axes for crystals belonging to the tetrahedral class. The peculiar development of Fig. 408 of tetrahedrite is to be noted. Fig. 410 is a twin of the ordinary spinel type of another tetrahedral species, sphalerite; with it, complex forms with repeated twinning are not uncommon and sometimes polysynthetic twin lamellæ are noted.

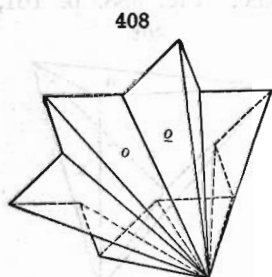

408  
Tetrahedrite

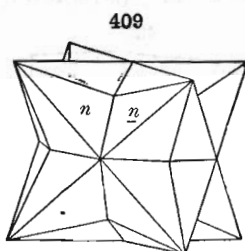

409  
Eulytite

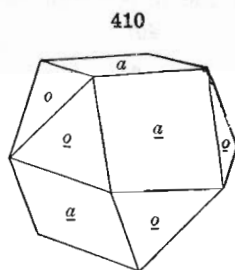

410  
Sphalerite

245. **Tetragonal System.** — The most common method is that where the twinning-plane is parallel to a face of the pyramid,  $e(101)$ . It is especially characteristic of the species of the rutile group — viz., rutile and cassiterite:

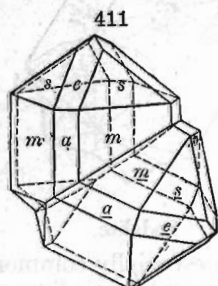

411  
Cassiterite

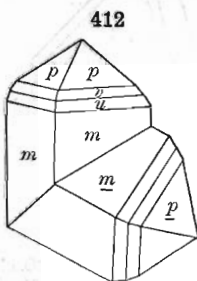

412  
Zircon

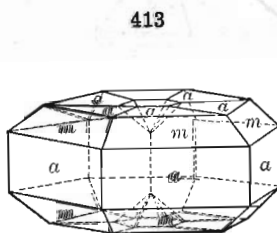

413  
Rutile

also similarly the allied species zircon. This is illustrated in Fig. 411, and

again in Fig. 412. Fig. 413 shows a repeated twin of rutile, the twinning according to this law; the vertical axes of the successive six individuals lie in a plane, and an inclosed circle is the result. Another repeated twin of rutile according to the same law is shown in Fig. 399; here the successive vertical axes form a zigzag line; Fig. 414 shows an analogous twin of hausmannite.

Another kind of twinning with the twinning-plane parallel to a face of the pyramid (301) is shown in Fig. 415.

**246.** In the *pyramidal* class of the same system twins of the type of Fig. 416 are not rare. Here the vertical axis, *c*, is the twinning-axis; such a crystal may simulate one of the normal class.

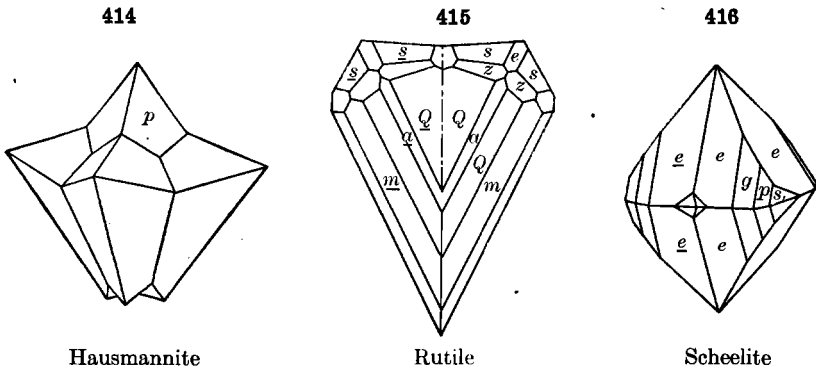

In chalcopyrite, of the *sphenoidal* class, twinning with a face of the unit pyramid,  $f(11\bar{1})$ , as the twinning-plane is common (Fig. 417). As the angles differ but a small fraction of a degree from those of a regular octahedron, such twins often resemble closely spinel-twins. The face  $e(101)$  may also be a twinning-plane and other rarer types have been noted.

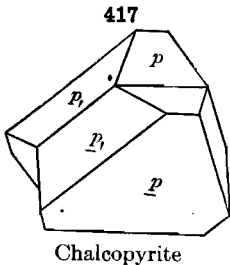

**247. Hexagonal System.** — In the *hexagonal* division of this system twins are rare. An example is furnished by pyrrhotite, Fig. 418, where the twinning-plane is the pyramid  $(10\bar{1}1)$ , the vertical axes of the individual crystals being nearly at right angles to each other (since  $0001 \wedge 10\bar{1}1 = 45^\circ 8'$ ).

**248.** In the species belonging to the trigonal or *rhombohedral* division, twins are common. Thus the twinning-axis may be the vertical axis, as in the contact-twins of Figs. 419 and 420, or the penetration-twin of Fig. 393. Or the twinning-plane may be the obtuse rhombohedron  $e(01\bar{1}2)$ , as in Fig. 421, the vertical axes crossing at angles of  $127\frac{1}{2}^\circ$  and  $52\frac{1}{2}^\circ$ . Again, the twinning-plane may be  $r(10\bar{1}1)$ , as in Figs. 422–425, the vertical axes nearly at right angles ( $90\frac{3}{4}^\circ$ ); or  $(02\bar{2}1)$ , as in Fig. 426, the axes inclined  $53\frac{1}{4}^\circ$  and  $126\frac{1}{4}^\circ$ .

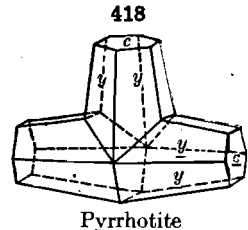

In the *trapezohedral* class, the species quartz shows several methods of twinning. In Fig. 427 the twinning-plane is the pyramid  $\xi(11\bar{2}2)$ , the axes crossing at angles of  $84\frac{1}{2}^\circ$  and  $95\frac{1}{2}^\circ$ . In Fig. 428 the twinning-axis is *c*, the

axes hence parallel, the individuals both right- or both left-handed but unsymmetrical,  $r(10\bar{1}1)$  then parallel to and coinciding with  $z(01\bar{1}1)$ . The re-

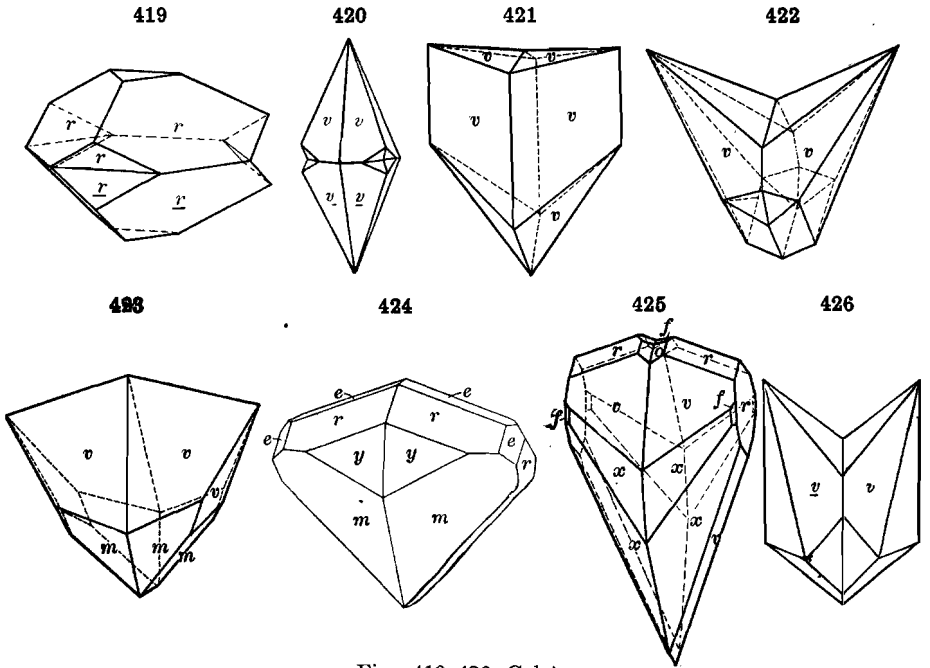

Figs. 419-426, Calcite

sulting forms, as in Fig. 428, are mostly penetration-twins, and the parts are often very irregularly united, as shown by dull areas ( $z$ ) on the plus rhombohedral face ( $r$ ); otherwise these twins are recognized by pyro-electrical phenomena. In Fig. 429 the twinning-plane is  $a(11\bar{2}0)$  — the *Brazil law* — the individuals respectively right- and left-handed and the twin symmetrical with reference to an  $a$ -face; these are usually irregular penetration-twins; in these twins  $r$  and  $\bar{r}$ , also  $z$  and  $\bar{z}$ , coincide. These twins often show, in con-

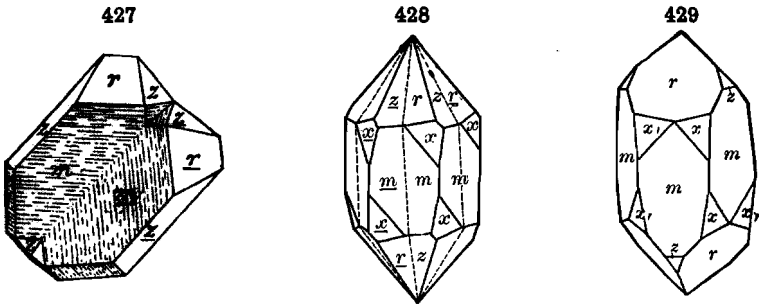

Figs. 427-429, Quartz

verging polarized light, the phenomenon of Airy's spirals. It may be added that pseudo-twins of quartz are common — that is, groups of crystals which

nearly conform to some more or less complex twinning law, but where the grouping is nevertheless only accidental

**249. Orthorhombic System.** — In the orthorhombic system the commonest method of twinning is that where the twinning-plane is a face of a prism of  $60^\circ$ , or nearly  $60^\circ$ . This is well shown with the species of the aragonite group. In accordance with the principle stated in Art. 241, the twinning after this law is often repeated, and thus forms with pseudo-hexagonal symmetry result. Fig. 430 shows a simple twin of aragonite; Fig. 431 shows a basal section of an aragonite triplet which although it resembles a hexagonal prism reveals its twinned character by the striations on the basal plane and by irregularities on its composite prism faces due to the fact that the prismatic angle is not exactly  $60^\circ$ . With witherite (and bromlite), apparent hexagonal pyramids are common, but the true complex twinning is revealed in polarized light, as noted later.

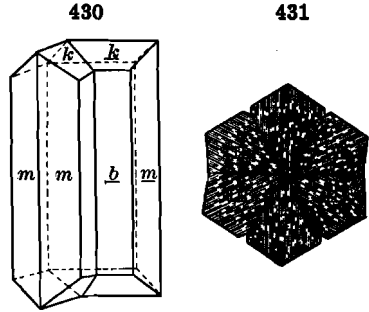

Aragonite

Twinning of the same type, but where a dome of  $60^\circ$  is twinning-plane, is common with arsenopyrite (tw. pl.  $e(101)$ ), as shown in Figs. 432, 433; also

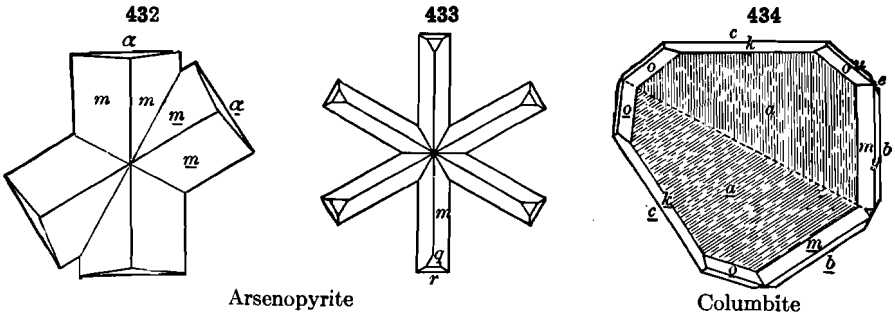

Arsenopyrite

Columbite

Fig. 434 of columbite, but compare Fig. 385 and remarks in Art. 238. Another example is given in Fig. 395 of alexandrite (chrysoberyl). Chrysolite, man-

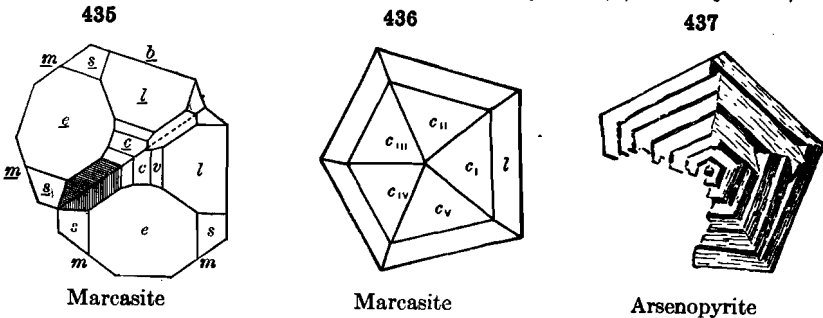

Marcasite

Marcasite

Arsenopyrite

ganite, humite, are other species with which this kind of twinning is common. Another common method of twinning is that where the twinning is parallel

to a face of a prism of about  $70\frac{1}{2}^\circ$ , as shown in Fig. 435. With this method symmetrical fivelings not infrequently occur (Figs. 436, 437).

The species staurolite illustrates three kinds of twinning. In Fig. 438 the twinning-plane is (032), and since  $(001 \wedge 032) = 45^\circ 41'$ , the crystals cross nearly at right angles. In Fig. 439 the twinning-plane is the prism (230). In Fig. 440 it is the pyramid (232); the crystals then crossing at angles of about  $60^\circ$ , stellate trillings occur (see Fig. 397), and indeed more complex forms. In Fig. 441 there is twinning according to both (032) and (232).

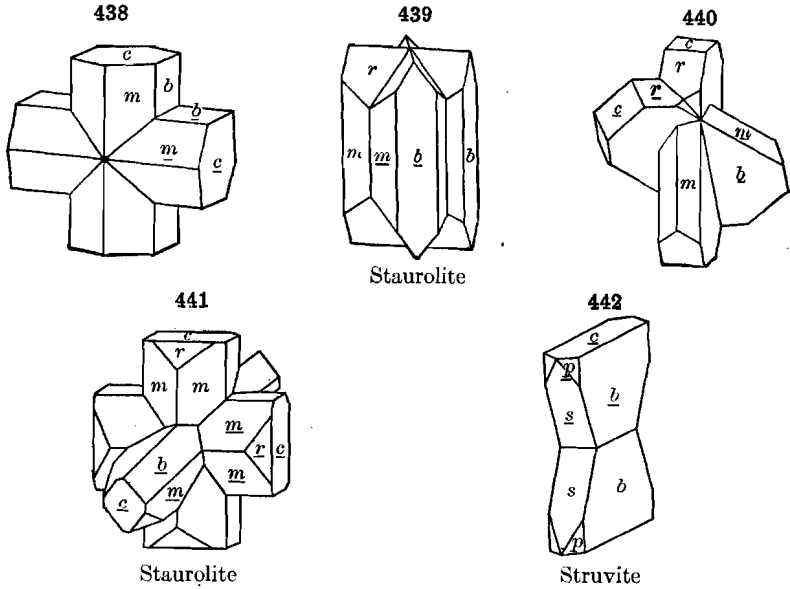

In the hemimorphic class, twins of the type shown in Fig. 442, with  $c(001)$  as the twinning-plane, are to be noted.

**250. Monoclinic System.** — In the monoclinic system, twins with the vertical axis as twinning-axis are common; this is illustrated by Fig. 443 of augite (pyroxene), Fig. 444 of gypsum, and Fig. 445 of orthoclase (see also Fig. 390,

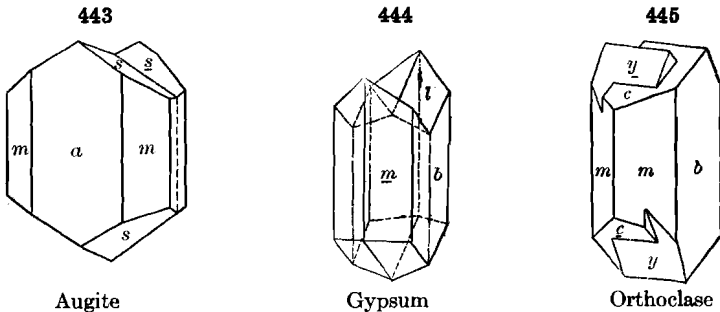

p. 162). With the latter species these twins are called *Carlsbad twins* (because common in the trachyte of Carlsbad, Bohemia); they may be contact-twins

(Fig. 390), or irregular penetration-twins (Fig. 445). In Fig. 390 it is to be noted that  $c$  and  $x$  fall nearly in the same plane.

In Fig. 446, also of orthoclase, the twinning-plane is the clinodome (021), and since  $(001 \wedge 021) = 44^\circ 56\frac{1}{2}'$ , this method of twinning yields nearly square prisms. These twins are called *Baveno twins* (from a prominent locality at Baveno, Italy); they are often repeated (Fig. 447). In Fig. 448 a

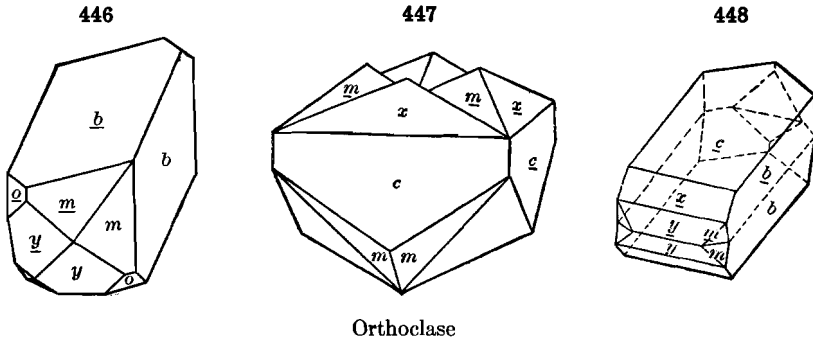

Orthoclase

*Manebach twin* is shown; here the twinning-plane is  $c(001)$ . Other rarer types of twinning have been noted with orthoclase. Polysynthetic twinning with  $c(001)$  as twinning-plane is common with pyroxene (cf. Fig. 461, p. 173).

Twins of the aragonite-chrysoberyl type are not uncommon with monoclinic species, having a prominent  $60^\circ$  prism (or dome), as in Fig. 449. Stellate twins after this law are common with chondrodite and clinohumite. An analogous twin of pyroxene is shown in Fig. 450; here the pyramid  $(\bar{1}22)$  is the twinning-plane, and since  $(010 \wedge \bar{1}22) = 59^\circ 21'$ , the crystals cross at angles of nearly  $60^\circ$ ; further, the orthopinacoids fall nearly in a common zone, since  $(100 \wedge \bar{1}22) = 90^\circ 9'$ . In Fig. 451 the twinning-plane is the orthodome

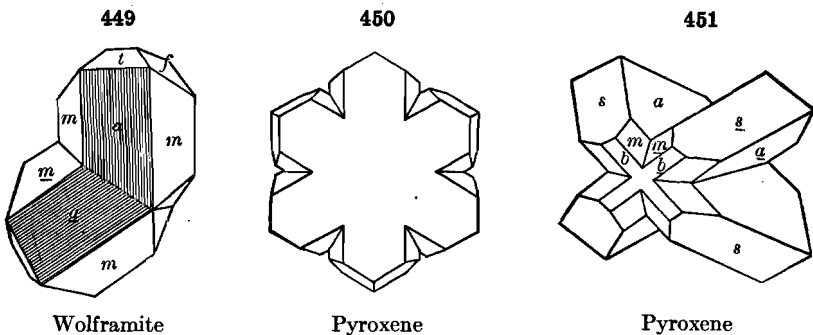

Wolframite

Pyroxene

Pyroxene

(101). Phillipsite and harmotome exhibit multiple twinning, and the crystals often show pseudo-symmetry. Fig. 452 shows a cruciform fourling with  $c(001)$  as twinning-plane, the twinning shown by the striations on the side face. This is compounded in Fig. 453 with twinning-plane  $(011)$ , making nearly square prisms, and this further repeated with  $m(110)$  as twinning-plane

yields the form in Fig. 454, or even Fig. 400, p. 164, resembling an isometric dodecahedron, each face showing a fourfold striation.

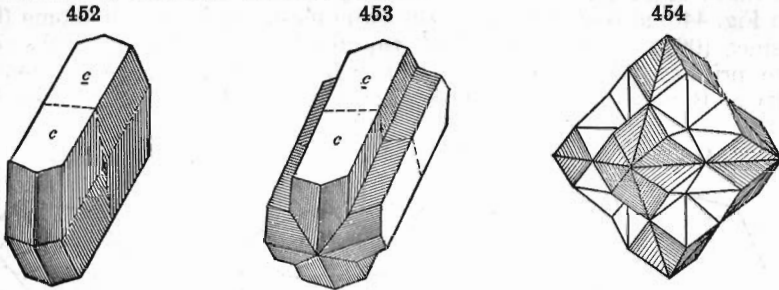

Phillipsite

**251. Triclinic System.** — The most interesting twins of the triclinic system are those shown by the feldspars. Twinning with  $b(010)$  as the twinning-plane is very common, especially polysynthetic twinning yielding thin parallel lamellæ, shown by the striations on the face  $c$  (or the corresponding cleavage-surface), and also clearly revealed in polarized light. This is known as the *albite law* (Figs. 455, 456). Another important method (Fig. 457) is that of the *pericline law*; the twinning-axis is the crystallographic axis  $b$ . Here the twins are united by a section (rhombic section) shown in the figure and further explained under the feldspars. Polysynthetic twinning after this law is common, and hence a cleavage-mass may show two sets of striations, one on the surface parallel to  $c(001)$  and the other on that parallel to  $b(010)$ . The angle made by these last striations with the edge  $001/010$  is characteristic of the particular triclinic species, as noted later.

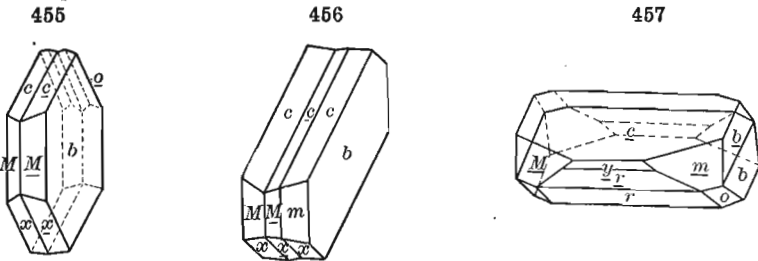

Albite

Twins of albite of other rarer types also occur, and further twins similar to the Carlsbad, Baveno, and Manebach twins of orthoclase. Fig. 458 shows twinning according to both the albite and Carlsbad types.

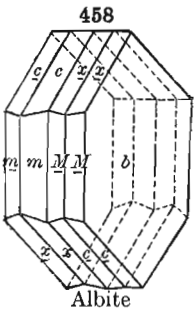

Albite

REGULAR GROUPING OF CRYSTALS

**252. Parallel Grouping.** — Connected with the subject of twin crystals is that of the parallel position of associated crystals of the same species, or of different species.

Crystals of the same species occurring together are very commonly in parallel position. In this way large